

THE MAINTENANCE BEACON

The Monthly Newsletter of the North Carolina Public School Maintenance Association

Volume 60, Number 8
August 2023

Contents

PIG PICKIN'	3
Travel Subsistence Rates	3
Obituary	4
Back to School	5
Jay Palmer Scholarship GT Sponsorship & Registraton Forms	7
Variable Speed Pump	
Part Six.....	8
Membership Application	9
D3 GT Annoucement.....	10
D3 GT Registration	10
DoubleTree Lodging Info.....	11
Overdose Awareness	11
Registration Forms.....	11 & 12
Of the Year Awards	12
Eastern Convention D7 GT Annoucement	13
D7 GT Registration	13
Eastern Convention Tentative Agenda.....	14

MEETING DATES

The districts of NCPSMA meet twice yearly.

District 1

January, July

District 2

January, July

Pres. Ronald Moore

Phone: 910.296.1875

District 3

February, August

Pres. Greg Woodard

Phone: 252.399.7822

District 4

February, October

Pres. Donna Fields

Phone: 910.678.2565

District 5

March, September

Pres. Justin Dyson

Phone: 336.909.2280

District 6

April, October

Pres. Chris Adkins

Phone: 980.343.4526

District 7

May, November

Pres. Jeff Adams

Phone: 336.551.1109

District 8

March, November

V. Pres. Jason Kelly

Phone: 828.456.2402

Meeting Dates & Locations

Should be sent to The Maintenance Beacon two months in advance for publication.

Deadlines

Publication deadline for articles and advertisements is first day of the month prior to month of publication.

Just a Friendly Reminder

The NCPSMA Membership year started over on July 1, 2023. A renewal form is available in this issue of *The Maintenance Beacon*. If you need an invoice or quote, please contact Kristie Payne at office@ncpsma.org or (828) 565-0115.

Message from your President

Hello friends,

As a new school year dawns upon us, I want to thank each and every one of you for your continued support of the North Carolina Public School Maintenance Association. I do want to give a special, thank you to all of the vendors who continue to financially support the association.

Without you providing the products and means for maintenance and facility departments across the state, our maintenance departments would not be able to function.

I also want to thank each and every one of the members for your valued support. Each of you, through your God-given talents day in and day out, prove your passion for this profession, by continually serving school districts and truly making a difference.

We appreciate all that you do!!

I hope that for everyone reading this note, has a fantastic start of a new school year. If I can be of assistance to you, please reach out to me.

May God Bless each of you and your families!

David Martin



Western Convention Exhibitor Photos



more photos on page 3

Meetings and Events

DISTRICT THREE MEETING

August 3, 2023 at 4:00 pm

Facility Services Building, 601-A West Market St., Smithfield, NC
For more info please contact D3 Secretary/Treasurer Sue Farmer at 252.399.7823 or sue.farmer@wilsonschoools.net

51ST ANNUAL NCPSMA EASTERN CONVENTION/WORKSHOP

September 26-29, 2023 DoubleTree by Hilton Atlantic Beach

For more info please contact Krisite Payne at 828.565.0115 or office@ncpsma.org

JAY PALMER MEMORIAL SCHOLARSHIP GOLF TOURNAMENT

September 27, 2023 at 1 pm

Brandywine Bay Golf Club, 177 Brandywine Blvd., Morehead City, NC
For more info please contact Tournament Director James Palmer III at 336.746.5000 or 336.239.1315 mobile

DISTRICT SEVEN GOLF TOURNAMENT

October 13, 2023 • Lunch at 12 pm • Tee Off 1 pm

Brushy Mtn Golf Course - 300 Golf Course Ln, Taylorsville, NC
For more info please contact Robert Hoyle or Kristie Gilbert with Catawba County Schools at 828.464.3562

DISTRICT THREE GOLF TOURNAMENT

October 27, 2023 • Lunch at 12 pm • Shotgun start at 1 pm

Wedgewood Golf Course, 3201 Old Stantonsburg Rd., Wilson, NC
For more info contact Sue Farmer at 252.399.7823 or sue.farmer@wilsonschoools.net

DISTRICT EIGHT FALL MEETING

November 14, 2023 at 6:00 pm

Nesbitt Discovery Academy, 175 Bingham Rd. Unit 10, Asheville, NC
For more info please contact Krisite Payne at 828.565.0115 or office@ncpsma.org

INDEX OF ADVERTISERS

ACI Systems	7
Atlantic Coastal Supply, Inc.	8
Davidson Sash & Door	5
D.H. Bruch Marketing, Inc.	6
Duro-Last Roofing	7
EduCon.....	4
Floor Action	10
Hardware Distributors.....	7
Hoffman & Hoffman	8
James M. Pleasants Co.....	4
John Q. Bullard.....	10
Ken Staley Co., Inc.....	6
Lewis Boiler Supply	10
Loman Garrett.....	3
Mannington Commercial.....	8
Matt Marshall & Co.....	7
Musco Lighting	10
Pinnacle Dryer Corp.....	7
Reece, Noland & McElrath.....	10
Richard K. Hunter & Co.....	5
Royalwood	6
Saffelle, Inc.....	10
Seating Safety Solutions.....	3
Seven Oaks Doors & Hardware	8
Seven Oaks Supply Co.	9
Sky Enterprises.....	8
The Blind Butler/Premier Drapery	9
The Cook & Boardman Group	2
WC Rouse	8



PROUDLY SUPPORTING NCPSMA MEMBERS

We're your premier provider of architectural doors and frames, door hardware and related building specialty products as well as complete system integration services including: physical security, enterprise networking, low voltage cabling and more!

Helping to Maintain North Carolina's Schools Since 1955

The Cook & Boardman Group of companies is your premier provider of integrated security solutions for building access control and occupant safety. We are the nation's largest distributor of commercial doors and hardware - and the sixth largest security systems integrator. With six convenient locations across the Tar Heel State, we're uniquely positioned to provide the best solutions for educational facilities. Allow us to offer you:

- Assessments
- Value engineering
- Specification review
- Project management
- Fire and life safety code compliance
- Installation, maintenance and service
- Product support/warranty management

To eliminate procurement headaches, choose our team to act as your single source for new construction and remodeling projects, as well as for any IT implementation. Contact your local branch to get started today!

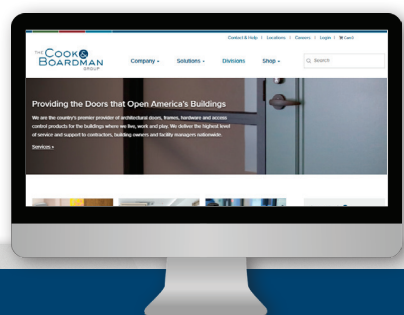
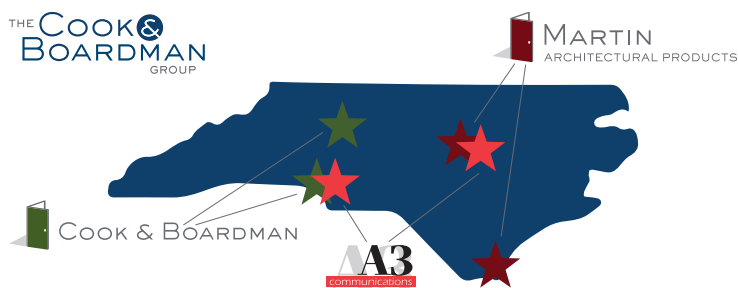

Visit www.COOKANDBOARDMAN.com to learn more about our group, find helpful resources and to place product orders.

Meet Your Local CBG Teams

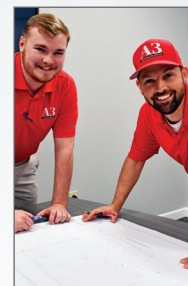

A3 Communications

Construction Divisions: 27 & 28

With offices in Charlotte and Raleigh, A3 Communications is one of the nation's leading systems integrators. Purchase both your IT and physical security needs from one of their many state contracts!

Contact: Kevin Wren | (803) 984-7007



Cook & Boardman

Construction Divisions: 8 & 10

With offices in Charlotte and Winston-Salem, Cook & Boardman has provided architectural doors, frames and hardware across the state since 1955. Counter sales, pre-installation, fabrication, installation and service available!

Charlotte Office: Rob Burnett | (704) 681-2627
Randy Beeson | (980) 417-0248

Winston-Salem Office: Mark Van Hoever | (336) 865-3734
Scottie Hentschel | (828) 446-9746



Martin Architectural Products

Construction Divisions: 8 & 10

With offices in Cary and Wilmington, Martin Architectural Products is the leading provider of architectural doors, frames and hardware in eastern North Carolina. Counter sales, installation and service available!

Cary Office: Ira Garner | (919) 868-6593
Wilmington Office: Kyle Praeuner | (402) 841-1345

Western Convention Exhibitor Photos

continued from page 1



more photos on page 4

Wednesday, September 27, 2023, 6:00–10:00 pm
"On the Rocks" Restaurant & Bar
2604 W. Fort Macon Road, Atlantic Beach, NC 28512
 Located across from the DoubleTree by Hilton Hotel

FREE OF CHARGE
 Limited to first 125 NCPMSA Members (spouses included)
 Must show Conference Name Badge to Enter

Karaoke

SPONSORING VENDORS

BIRS, Inc. D H Bruch Marketing, Inc. The Garland Company Hardware Distributors, Inc.	Hoffman & Hoffman Matt Marshall & Company Saffelle, Inc. Seven Oaks Doors & Hardware
---	---

This notification provided by:
MATT MARSHALL & CO.

New Travel Subsistence Rates

Kristen Walker, State Budget Director from the State of North Carolina's Office of State Budget and Management released revised Travel Subsistence Rates effective July 1, 2023.

Pursuant to G.S. §138-6(5), the Director of the Budget is required to revise subsistence payments for state employees' in-state and out-of-state travel. The revision is based on the percentage increase in the Consumer Price Index for All Urban Consumers for the most recent 24-month period. Effective July 1, 2023, total subsistence reimbursement rates will be increased by approximately 13.0% for both in-state expenses and out-of-state expenses. The new subsistence rates will be effective for both years of the 2023-25 biennium.

The following list details the various rates of subsistence per day for travel-related expenses. A revision to the State Budget Manual will be issued to reflect this change.

	In-State	Out-of-State
Breakfast	\$ 10.10	\$ 10.10
Lunch	\$ 13.30	\$ 13.30
Dinner	\$ 23.10	\$ 26.30
Lodging (actual, up to)	\$ 89.10	\$ 105.20
Total	\$ 135.60	\$ 154.90

SEATING SAFETY SOLUTIONS, INC.

The Carolinas' Largest Factory Backed Bleacher Service and Repair Company

(336)622-1678 • www.seatingsafetysolutions.com

- Indoor/Outdoor Bleachers
- Grandstands
- Auditorium Seating
- Arena Seating
- Lecture Seating
- Basketball Backstops



Wall Mount Equipment and Parts!

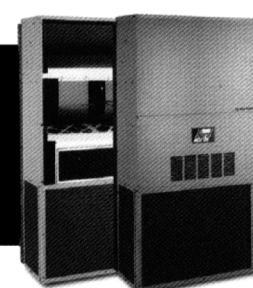

50% Quieter
20% More Efficient

And ... "Service Simple"

Loman Garrett
 Precision Climate Management
800-669-1761

Obituary

Jean Neville Saffelle

Jean Neville Saffelle of Chapel Hill, N.C. died on July 6, 2023 at Duke Hospital after a long battle with Leukemia. She passed peacefully with family surrounding her with music and stories.



She was born on November 19, 1938 in Chapel Hill, NC to the late Eugene (Red) Claude Neville and Irma (Chatham) Neville. Growing up in Chapel Hill her parents, sister and brother loved and supported each other throughout their lives. Every holiday was spent at her parents' home on Dairyland Road with the family. After the passing of her parents, she continued the tradition at her home on Thanksgiving and Christmas. Family mattered more to her than any beauty contest she won or business she ran.



After taking business classes at UNC, she met her future husband, Milton Franklin Saffelle, on a blind date. Married on August 25, 1962, they raised three children and started a business together. Saffelle, Inc. was the product of hard work and dedication. She loved all the employees that worked there and welcomed them as family.

She was a loyal TarHeel fan, a CHHS majorette, a Miss Dairy Queen 1955, a 1957 Sweetheart of Chapel Hill High and a Miss Carrboro Cub. Known for her beauty inside and out, her sense of style and class, her strength, her pink lipstick, her love for her children, grandchildren, and husband, she will be deeply missed.

She leaves behind her loving husband of 60 years, Milton Franklin Saffelle, Chapel Hill, NC. Her children, Jeanine Saffelle Mangieri (Frank), Mark Neville Saffelle (Lea) of Chapel Hill, and Christopher Scott Saffelle (Michele), Cary, NC. Her sister Lajaynees (Jan) Gilchrist and brother Bobby Neville (Jean). Her beloved grandchildren, Devin Rudolph, Jackson Rudolph, Bradley Saffelle, Morgan Saffelle, Alex Saffelle, Kate Saffelle, and Andrew Saffelle. And many cousins, nieces, and nephews...

Jean's family wants to express their appreciation to the caring doctors, nurses, and staff at Duke Hospitals. A viewing and slide show of her life will be held on July 16, 2023 from 1pm-2pm, at Antioch Baptist Church, 1707 White Cross Road, Chapel Hill, NC 27516. Service will begin at 2pm with burial following immediately afterwards.

Walker's Funeral Home of Chapel Hill is assisting the Saffelle family.

Western Convention Exhibitor Photos

continued from page 3



more photos on page 5



HYDRONIC AND STEAM EQUIPMENT, PUMPS, HEAT EXCHANGERS, COOLING TOWERS, WATER SOURCE HEAT PUMPS, PLUMBING



Geothermal Heat Pump Systems



CONDENSING BOILERS
WATER HEATERS



Bell & Gossett
CENTRIFUGAL PUMPS
HEAT EXCHANGERS



HYFAB
HYDRONIC PACKAGES
PRESSURE BOOSTERS



BAC
COOLING TOWERS

James M. Pleasants Company
Greensboro-Charlotte-Raleigh-Wilmington
www.jpcco.com
800-365-9010

Save the Date

NCPSMA invites you to participate in the
Annual Jay Palmer Memorial Scholarship
Golf Tournament

SCHOLARSHIP

GOLF

tournament

Wednesday
September 27, 2023

Brandywine Bay Golf Club
177 Brandywine Boulevard, Morehead City, NC



Sponsored by

Questions? Contact Kristie Payne at
office@ncpsma.org or (828) 565-0115



ENERGY MANAGEMENT WHERE IT BELONGS

EduCon Inc.
Winston-Salem, North Carolina
336-409-4694
info@educonenergy.com
www.educonenergy.com

EduCon can assist Maintenance Departments with:

- ✓ Uploading existing utilities data, or creating a new utilities database in the EPA's Portfolio Manager
- ✓ Enter information from monthly utilities invoices
- ✓ Prepare monthly and annual reports that include summarized data analysis



It's Back to School

Summer is over and "It's Back to School" for most students. But how often do you think about how education in the United States started? What was the vision for schools when our nation founded it. We have come a long way in education since our country's beginning.

In 1635 the first public school, The Boston Latin School, opened in the United States. To this day, it remains the nation's oldest public school. However, early public schools focused on the virtues of family, religion and community instead of academics like math and reading. And at that time girls were taught how to read but not write.

In the south, public schools were not common during the 1600s and early 1700s but were more common after the American Civil War. Children were only education if their families could afford private tutors.

After the Revolutionary War, Thomas Jefferson believed there should be an education system that was supported by taxpayer dollars. However, the government did not enact this for nearly a century after his proposal.

The 18th century saw the emergence of common schools. These schools had one teacher in one room to educate students of all ages. Parents had to pay for their children to attend and sometimes this would be in the form of housing or other materials instead of money.

One of the first major developments in education came in 1783 with *The American Spelling Book* by Noah Webster. It set spelling and grammatical standards for the English Language in America. Noah Webster is quoted, "Every child in America should be acquainted with his own country. He should read books that furnish him with ideas that will be useful to him in life and practice. As soon as he opens his lips, he should rehearse the history of his own country." In 1828 he made another contribution to education with his *American Dictionary of the English Language* which heavily influenced the American dialect and in 1840 he published his second volume.

Massachusetts was the first state to create a Board of Education in 1837 and by this time they had already established free public schools for every grade. A state legislator, Horace Mann started this education structure. He believed education could bridge all kinds of societal and economic gaps. He believed schools should be free to everyone because education could provide wealth and opportunities.

The United States Department of Education was founded in 1867 and helped establish a national standard for education.

By 1900, 31 states had mandatory school attendance for students from ages 8-14 and by 1918 every state required students to complete elementary school.

Beginning in the late 1800's through the 1930's, education took a new turn with John Dewey leading the charge with the idea of educating a child to reach his full potential and actively promoting and participating in a democratic society.

Despite the 1954 *Brown vs. Board of Education* ruling the United States had racially segregated schools through the 1960s. But by the late 1970's, the US eradicated segregated schooling.

In 1965, Title I of the *Elementary and Secondary Education Act* was passed, which established the federal government's expanded role in public education and gave additional funding to local schools educating socioeconomically limited children. In 2001, the United States entered the era of education accountability with the institution of the *No Child Left Behind* law. It had standards-based testing reforms and penalties for schools that fail to meet adequate yearly progress goals. But in December 2015 the United States passed a law for a new act, *Every Student Succeeds Act*. This law replaced its predecessor and modified but did not eliminate provisions relating to the periodic standardized tests given to students.

Currently the Biden Administration is working to create an educational program that would involve 17 years of school attendance instead of the traditional 13-year method. Under this proposed plan, pre-kindergarten would be available for three-year-old children, and the first two years of community college would be free.

Kristie Payne

Western Convention Exhibitor Photos

continued from page 4



more photos on page 6

WALKWAY COVERS

REPLACEMENT WINDOWS

Phone 336-249-0276 Fax 336-249-7750

Davidson Sash & Door, Inc.
1358 Piedmont Drive, Lexington, N.C. 27295-1952

Without compromise | 1887

Weil-McLain redefines heating all over again.

Richard K. Hunter & Co.
Manufacturer's Agent
3714 Alliance Drive, Suite 405, Greensboro, NC 27407
712 West Lexington Ave., Suite 201, High Point, NC 27262
PO Box 5105

Call your distributor or visit www.weil-mclain.com to learn more.

Western Convention Exhibitor Photos

continued from page 5





ABH Manufacturing

Dormakaba, USA

- Best Locks, Closers, Hinges & Exit Devices (PHI)
- dormakaba Closers, Locks, Exit Devices & Commercial Hardware

National Guard Products

Overly Door Company

Security Door Controls

Trimco Hardware

Door & Hardware Representatives

(704) 588-5214

352 Crompton St.
Charlotte, NC 28273

Providing Great Service for 59 years



Royalwood Associates
Specialty Flooring

Serving North Carolina, South Carolina & Virginia for over three decades.

www.royalwood.us
919-957-3006



Specializing in Wood & Synthetic Flooring Services for Public & Private Schools:

- Annual Screening & Recoating
- Sanding & Refinishing
- Court line & logo painting, staining, tinting & design
- Resurfacing (pad & pour)
- Installation & design of new wood & synthetic floors

Gymnasiums, Weight Rooms, Dance Rooms, Stages, Running Tracks, Multi-purpose Rooms, etc.



For more information contact Greg Serpas at 336-707-9976 or greg@royalwood.us

KEN STALEY COMPANY, LTD

4675 ROUTE 64 • BUILDING #16 • FRANKLINVILLE • NC 27248 • www.bleacher101.com

OFFICE: 336.685.4294 • FAX: 336.685.4242 • EMAIL: bleacher101@hotmail.com

BLEACHERS

GYM & OUTDOOR

- Safety Inspection & Repair Work
- Annual Service Program Offered
- Handicap Areas
- Full Power Electrical Systems
- Portable Power Systems
- Safety Rails
- Outdoor Seating Sales and Installation
- Authorized & Certified • Bleacher Installers
- Basketball Goals Installed and Repaired

MORE THAN 40 YEARS OF SERVICE

SEE US FOR ALL OF YOUR BLEACHER NEEDS!



Duro-Last®; the most water, wind and worry-resistant roof in the business.

Duro-Last's industry leading warranties are supported by prefabrication of roof panels and membrane accessories in a factory quality controlled environment. This eliminates up to 85% of field welding. Our highly trained technical field team inspects the field welded seams. Once you put a Duro-Last roof on, you can put it out of your mind.

Edge-to-Edge & Deck-to-Sky™

Bill Paynter 919-265-9045 Eastern NC	Jim English 980-875-8187 Western NC
--	---

DURO-LAST
THE WORLD'S BEST ROOF™
Visit duro-last.com
or call to find out more.

22ND ANNUAL JAY PALMER MEMORIAL SCHOLARSHIP GOLF TOURNAMENT SPONSORSHIP OPPORTUNITY

SPONSORED BY: John Labban, PREMIER SUPPLY, INC.
Opportunities to Sponsor: The tournament will be played during the NCPSMA fall conference at Atlantic Beach, NC on Wednesday, September 23, 2023 at the Brandywine Bay Golf Club.

SPONSORSHIPS AVAILABLE

Check the sponsorship you prefer and complete the information at the bottom of the page

- A. _____ **GOLD** - \$500 GOLD SPONSOR
Includes a sign with your name on the tee of one hole
- B. _____ **SILVER** - \$250.00 SILVER SPONSOR
Includes a sign with your name on one hole
- C. _____ **BRONZE** - \$125.00 BRONZE SPONSOR
Includes sign with your name on one hole
- D. _____ **HOLE SPONSORS** - \$100 gets a sign on the tee box of a hole
- E. _____ **Golf BALLS** - \$600 - Includes with logo (one sleeve in each golfer's good bags), 2 Golfers, Name listed on a Sponsor's Poster at Registration Table, sign on a Tee Box of one hole, Opportunity to place items in Golfer Goodie Bags.
- F. _____ **GOLFER DIVOT TOOL WITH MARKER** - \$450 - Includes 1 Golfer, Name listed on a Sponsor's Poster at Registration Table, sign on a Tee Box of one hole, Opportunity to place other items in Golfer Goodie Bags.
- G. _____ **HOLE IN ONE CONTEST - (\$1000 TRAVEL PRIVLEDGE CARD)** - \$400 - Includes 1 Golfer, Name listed on a Sponsor's Poster at Registration Table, sign on Tee Box of the Par 3, Opportunity to place other items in Golfer Goodie Bags.
- H. **GOLFER GOODIE BAGS** - \$350 - Includes 1 Golfer, Bag will have company Logo (each player will receive one upon check-in), Name listed on a Sponsor's Poster at Registration Table, sign on a Tee Box of one hole, and the Opportunity to place items in the Golfer Goodie Bags.
- I. **CLOSEST TO PIN** - \$200 - Includes 1 Golfer, Gift for a par 3 Hole, Sign on the Tee Boc of the hole, Name listed on a Sponsor's Poster at Registration Table, and the Opportunity to place items in the Golfer Goodie Bags.
- J. **LONGEST DRIVE** - \$200 - Includes 1 Golfer, Gift for the Hole, Sign on the Tee Box of the hole, Name listed on a Sponsor's Poster at Registration Table, and the Opportunity to place items in the Golfer Goodie Bags.
- K. **DOOR PRIZES** - If you have items with your company logo that you might be willing to donate for a drawing with our players that would be greatly appreciated as well!!!

Simply complete the following and return **prior to August 7, 2023**

Name of Individual Placing Ad _____
 Company or Organization _____
Mailing Address
 Street _____
 City _____ State _____ Zip Code _____
 Telephone _____ Email Address * _____

If a golfer is included in the Sponsorship, please complete a Tournament Registration form as well.
Mail to: JAY PALMER SCHOLARSHIP TRUST FUND, C/O James Palmer, III
6735 EAST OLD US HWY 64, LEXINGTON, NC 27292
FAX # (336) 746-5005 or E-mail to: james_marie@lexcominc.net
Questions - Call James Palmer, III (336) 746-5000 res. (336) 239-1315 cell

PLEASE FOLLOW UP WITH AN EMAIL TO VERIFY YOUR SPONSORSHIP!!!
THANK YOU FOR YOUR SUPPORT!

22ND ANNUAL JAY PALMER MEMORIAL SCHOLARSHIP GOLF TOURNAMENT REGISTRATION FORM

Sponsored by: Premier Supply, Inc.

DATE: Wednesday, September 27, 2023

LOCATION: Brandywine Bay Golf Club

177 Brandywine Boulevard, Morehead City, NC 28557 - 252.247.2541

ENTRANCE FEE: \$65 (prior to 9/18/23) \$70 (after 9/18/23)

Fee Includes: Car and Green Fees, Range Balls, Lunch, Goodie Bags & Prizes

Net Score will be handicapped by Callaway System

Make checks payable to JPSTF

Prizes and Awards

*Low Gross - 1st and 2nd

*Low Net - 1st and 2nd

*Longest Drive & *Closet to Pin

Two Division this year for Maintenance Personnel and Sales Personnel

Complete and Return Your Application Prior to September 20, 2023

Course requesting numbers of players

NAME: _____
 ADDRESS: _____
 SCHOOL SYSTEM: _____ DISTRICT __1__2__3__4__5__6__7__8
 COMPANY NAME: _____

Return to: **Tournament Director - Jay Palmer Scholarship Trust Fund**
 C/O James Palmer, III - 6735 East Old US Hwy 64, Lexington, NC 27292
 Phone: (336) 746-5000 - Mobile: (336) 239-1315

BOILER-BURNER / SALES & SERVICE
MATT MARSHALL & CO.
 INDUSTRIAL EQUIPMENT & SUPPLIES
 GREENSBORO, N.C.
 PH: 336-292-8477 FAX: 336-299-0249
 1-800-632-1274
 Email: Sales@MMCO.net

"Call us for your boiler room supplies."

• ASCO "REDHAT" VALVES	• ITT GENERAL CONTROLS
• BACHARACH	• MAXITROL
• BELL & GOSSETT	• McDONNELL-MILLER
• CONBRACO	• SPIROTHERM
• ELECTRODES	• THERMOMETERS
• FIREYE	• TOPOG-E GASKETS
• GAUGES	• TRANSFORMERS
• HONEYWELL / RM 7800	• WATTS VALVES

WWW.MMCO.NET Email: Sales@MMCO.net
 ★ *Serving Industry Since 1954* ★
"Steam Is Our Specialty"



DON'T REPLACE IT... RESTORE IT!



WE OFFER:	ADHERES TO:
<ul style="list-style-type: none"> • Cost effective installation • Leak proof warranties • Seamless roof systems • Eco-friendly materials • Energy Star products 	<ul style="list-style-type: none"> • Modified Bitumen • Single-Ply (TPO & EPDM) • Metal Roof panels • Smooth Built-Up-Roof • Spray Foam

(888) 233-5997 Greensboro, NC www.roofsbyaci.com @RoofsbyACI



PINNACLE
 DRYER CORPORATION

Vandal-Resistant
 Automatic and Quiet
 Touch-Free
 Low Maintenance
 Made in USA!



Call 844-518-0997 Statesville, NC
www.PinnacleDryer.com

Hardware Distributors, LLC
 a Kendell Door & Hardware Company

Architectural Wood Doors, Hollow Metal Frames & Doors,
 Washroom Accessories & Toilet Partitions
 Installation service available

PO Box 16847
 Greensboro, NC 27406
 1-800-632-1324

SEVEN OAKS DOORS & HARDWARE, INC.
www.SevenOaksHardware.com

Call us for all your doors, hardware, access control, and toilet partition needs.

Oakboro, NC
704-485-2014

Authorized Security Center
ALLEGION

W.C. ROUSE & SON
BOILER ROOM EQUIPMENT & SERVICES

24 hours a day, 7 days a week

Our purpose is simple: To leave every boiler room better than we found it.

Offering:

- 24/7 Service
- Parts, for all Boiler Brands
- Boilers, of All Constructions
- Boiler Ancillary Equipment
- New, Used and Rental Equipment

Greensboro, NC 336-299-3035
Charlotte, NC 704-583-4005
sales@wrouse.com wrouse.com
Wilmington, NC 336-299-3035
Columbia, SC 803-765-1477

HOFFMAN & HOFFMAN, INC.

MAKING INDOOR AIR SAFER

HVAC system solutions to improve your indoor air quality and help protect building occupants.

Solutions from trusted manufacturer's like:

24/7/365 Parts Available
(800) 332-2295

www.hoffman-hoffman.com (336) 292-8777

Mannington COMMERCIAL

Product Offerings

- Luxury Vinyl Tile
- Modular Carpet
- Broadloom Carpet
- Entrway Carpet
- Area Rugs
- Resilient Sheet
- Rubber Sheet & Tile
- Legato Liquid Linoleum
- Finishing Accessories

Please Reference:
Floor Covering & Installation Services for State of North Carolina (Contract 360)

Crafted with Purpose manningtoncommercial.com

SKY ENTERPRISES, INC. (252) 522-1435 • 1-800-729-0590
Water Treatment Specialist PO Box 1764 • Kinston, N.C. 28503

Cooling Towers Softners
Hot & Cold Water Loops Boilers
Pumps Timers Controllers

Atlantic Coastal Supply, Inc.
Plumbing & Industrial Specialties

www.acsparts.net
PO Box 2887
Greenville, NC 27836
Phone: 800.520.0556 • Fax: 800.204.5630 • Email: sales@atlanticcoastalsupply.com

Variable Speed Pump

Control in the Age of ASHRAE 90.1-2010/13 • Part Six

When Too Many Misses Occur

Frequent misses are fairly common in variable speed systems that utilize a curve control strategy. When misses occur, coils can become starved of flow. This results in unsatisfactory space temperatures and often uncomfortably high humidity levels, which leads to occupant complaints. The inevitable response is to increase the control head on the pumping system. Over time these adjustments cause the control head to creep up, sometimes exceeding efficiency parameters set by ASHRAE which require a control head of no greater than 40% of the total system head.

Consider the pumping system shown in Figure 23 which utilizes curve control and has only manual balancing. With only the zone closest to the pump open and calling for full flow (200 GPM), 68.7 feet of head is needed to overcome the resistance in that zone. However, if the pump control automatically defaults to 40% design head, only 36 feet of head will be available, giving us only 145 GPM of flow through the coil. Depending on the flow tolerance of the coil, this miss will likely result in complaints. The facility manager will likely respond by increasing the system control head, appeasing the occupants but significantly increasing operating cost. Furthermore, the system may no longer comply with ASHRAE 90.1.

Unfortunately, this has become an all too common problem due to the increasing number of curve controlled systems. The greater load diversity in the system, the more likely this is to be a problem.

A Lesson in Area Control

Systems with high load diversity are far more suited to area control than curve control.

Differential pressure (DP) sensors play a crucial role in an area control strategy by providing feedback to the pump controller to speed up or slow down the pump as

continued on page 9

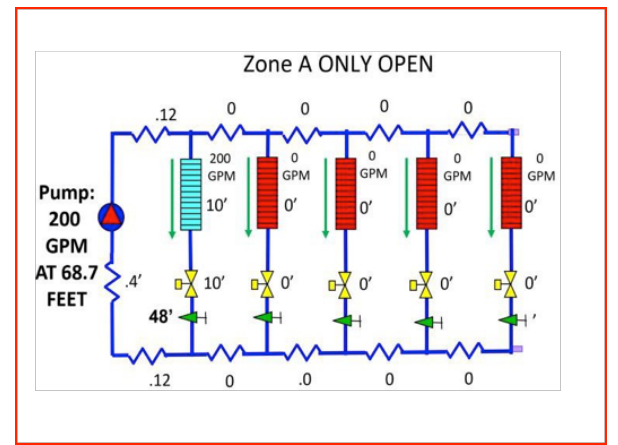

Figure 23

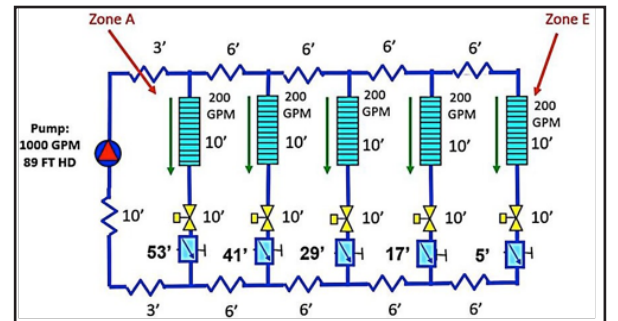

Figure 24

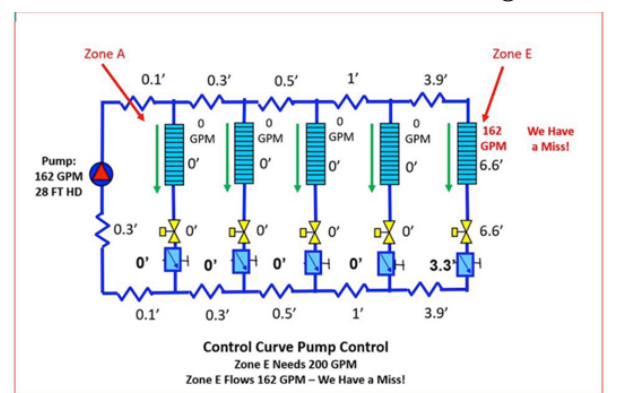

Figure 25

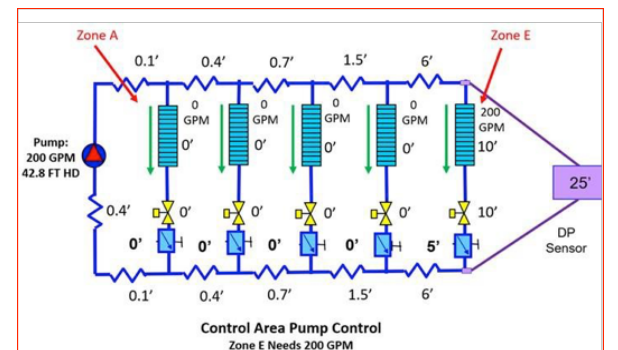

Figure 26

THE MAINTENANCE BEACON

Executive Director: Kristie Payne
Phone: 828.565.0115
E-Mail: office@ncpsma.org
Website: www.ncpsma.org

The Maintenance Beacon is the monthly publication of the North Carolina Public School Maintenance Association. Advertising, editorial material, memberships and subscriptions are handled through the office of the Executive Director, 224 Mulberry St. Clyde, NC, 28721.

NCPSMA does not guarantee, warranty or defend the use of any products or services of those who sponsor, advertise or contribute articles in The Maintenance Beacon.

Officers of the Association

President David Martin 704.658.2630 or dmartin@mgd.k12.nc.us
Vice President Mark Letchworth 252.399.7822 or mark.letchworth@wilsonschoolsnc.net
Secretary Jodene Abney 910.678.2488 or jodeneabney@ccs.k12.nc.us
Liasion Officer Chris Campbell 828.635.8248 x 303 or chriscampbell@alexander.k12.nc.us
Immediate Past President Bergie Speaks 336.667.2021 x 4009 or speaksb@wilkes.k12.nc.us

Variable Speed Pump Control in the Age of ASHRAE 90.1-2010/13 • Part Six

continued from page 8

needed to maintain the control head. With curve control, that head is planted squarely on the control curve. With area control, you've got more room to play. This comes in handy when you are working with systems that have a lot of diversity. In both cases, flow limiters or pressure independent control valves will help owners avoid misses under certain circumstances. These automatic balance devices help by unloading pressure drop at part load conditions.

Notice that the system in Figure 24 utilizes automatic flow limiting balancing valves at each zone. If we are using a curve control pump control strategy without a differential pressure sensor at the most critical zone, they will do a fairly good job satisfying flow demand, but there are exceptions.

The worst-case scenario with this balance type occurs when all the load is in the most remote (critical) zone. So, what happens in our example system if we have full load in Zone E and no load in the other zones?

In that case, we will have a miss in Zone E (Figure 25).

Zone E is calling for 200 GPM, but we only get 162 GPM using a curve control strategy. To get the full 200 GPM through Zone E, we need a total of 42.8 feet of head. However, because we are using curve control, we only have 28 feet of head available to flow water through Zone E, which only gives us 162 GPM of flow. To stay within ASHRAE's requirement of 97% heat transfer, we have to maintain at least 90% of the design flow through that coil or 180 GPM.

We can solve this problem by adding a DP sensor to Zone E, which effectively changes our variable speed control strategy into area control strategy. With a DP providing feedback to the pump controller, we can make sure that our available head across the critical zone never drops below our control head, which in this example is 25 feet. This gives us 42.8 feet of pump head at this particular part load condition – enough to flow 200 GPM through Zone E (Figure 26).

The remote DP sensor operates within the control area instead of being bound to the control curve. Combined with automatic flow limiters or pressure independent control (PIC) valves, the approach provides better (and more efficient) load matching.

One word of caution when it comes to using PIC valves on variable speed systems that incorporate reset control. ASHRAE 90.1-2010/13 requires that

facilities with building management systems (BMS) must continuously reset the control head based on the valve position so that under the least loaded conditions there is just enough head available to keep the most critical valve nearly wide open. This means that the position of each valve in the system must be monitored. However, differential pressure changes do not impact the flow through a PIC valve or its position. A built-in pressure regulator compensates for those increases and decreases in pressure, so the valve position doesn't change when the control head is reset. The only time the valve position will change is when differential pressure is lowered to the point that the valve is no longer in its control range. When this happens, we are no longer in control and are at risk of a big coil flow miss.

continued in September issue



Seven Oaks
SUPPLY COMPANY
CUTTING-EDGE CLEANING CONCEPTS

YOUR #1 SOURCE FOR...

- CUTTING-EDGE FLOOR CARE PRODUCTS
- RESTROOM CLEANING PROGRAMS
- ODOR CONTROL
- FLOOR CLEANING EQUIPMENT
- PAPER PRODUCTS & DISPENSERS

800-230-7460
OAKBORO, NC



premierdraperycleaning.com
O: (910) 794-1664

All the world's a stage and we're here to clean it!™
Stage Draperies • Acoustical Panels • Upholstery • Flameproofing

The Southeast's premier service for on-site cleaning, flame retardant application, and certification

MEMBERSHIP APPLICATION

Membership runs from July 1, 2023 through June 30, 2024.

Membership Dues are \$20.00 if paying by check. Complete this form and submit along with your check for \$20.00 to: **NCPSMA, 224 Mulberry Street, Clyde, NC 28721**

NAME			
LEA (Local Educational Agency) OR COMPANY			
ADDRESS			
CITY	STATE	ZIP	
TELEPHONE			
E-MAIL			
Would you like a reminder sent to your e-mail each month when the latest edition of the Maintenance Beacon is available online?			YES <input type="checkbox"/>
			NO <input type="checkbox"/>

MEMBERSHIP TYPE	
REGULAR MEMBERSHIP	Available to all maintenance employees of various city, county, and state public schools as well as institutions of the community colleges.
REGULAR RETIRED MEMBER	Available to all RETIRED maintenance employees of various city, county, and state public schools as well as institutions of the community colleges.
ASSOCIATE MEMBER	Available to all people interested in the betterment of public-school maintenance including school board members, superintendents, principals, teachers, and vendors. ** Associate Members DO NOT have voting privileges.

MEMBERSHIP	<input type="checkbox"/> Continuation of Current Membership
	<input type="checkbox"/> First Time Member

Are you the Maintenance Director / Supervisor of your LEA? YES NO

Online payments of \$21.00 per membership are accepted at www.ncpsma.org

Online payments of \$21.00 per membership are accepted at www.ncpsma.org

FOR OFFICE USE ONLY	
PAID FOR WITH CASH or CHECK #	RECEIPT #

District Three Golf Tournament Save The Date



WEDGEWOOD PUBLIC GOLF COURSE WILSON, NC
FRIDAY, OCTOBER 27, 2023
RAIN DATE – FRIDAY, NOVEMBER 3, 2023
1 PM SHOTGUN START

NCPSMA Annual Golf Tournament District III Superball Tournament

DATE: October 27, 2023

RAIN DATE: November 3, 2023

PLACE: Wedgewood Golf Course 3201 Old Stantonsburg Road, Wilson, NC

Entry Fee: \$50.00 per person
 \$200.00 per team

(THIS INCLUDES: GREEN FEE, RANGE BALLS, CART & LUNCH)

ALL CHECKS: PAYABLE TO: NCPSMA DISTRICT III

REGISTRATION FORM and PAYMENT FOR HOLE SPONSORSHIP AND TEAMS ARE DUE BY OCTOBER 21, 2022

!!!!!!!!ATTENTION!!!!!!!!

!!!!IF PAYMENT IS NOT RECEIVED BY THIS DATE YOU CANNOT PARTICIPATE!!!!

LUNCH AT NOON

Shotgun start at 1:00 PM

Hole Sponsorship: \$100 per hole

Prizes Include: Low Score, Closest To Pin, Longest Drive

Mulligan's: \$5.00 Each (MAX) 2

COMPLETE:

Team Name: _____

Team Players Names: _____

Address: _____

School Unit or Company: _____

RETURN TO:

Wilson County Schools – Maintenance Department
 PO Box 3878, Wilson, NC 27895
 Attention: Sue Farmer-Golf Tournament
 Phone – 252-399-7823
 Fax – 252-243-7197
 Email: sue.farmer@wilsonschoolsnc.net

John O Bullard
 Here to help you with all your Pump, Boiler,
 Hydraulic & Steam Accessory Needs.
www.jobullard.com | 919.509.6417

Floor Action

Serving your area for over 30 years

We install, repair and refinish all types of floors. Bleacher repair and inspections. Fire and water damage restorations. Power volleyball inserts and installation.

Patrick Morningstar, Owner
Josh Walton, Sales

Toll Free 800.745.6116 Fax 252.291.8042
 Local 252.291.6116 scsbyflooraction@gmail.com

*“Responding to Modern Engineering Challenges
 With Innovative, Cost Effective Solutions”*

RNM ENGINEERS
Reece, Noland & McElrath, Inc.
 409 North Haywood Street / PO Box 540
 Waynesville, NC 28786
 Waynesville (828) 456-9851 Asheville (828) 253-3280
 Fax (828) 456-6205

WWW.RNM-ENGINEERS.COM

Saffelle, Inc.
 SANITARY MAINTENANCE EQUIPMENT & SUPPLIES
“Partnering with a Passion”
1-800-672-4525
 GREEN EARTH
www.saffelle.com

MUSCO Lighting
We Make It Happen.
 Your Sales Representative is:
Dina Neeley
 Mobile: 336.414.1030
 Email: dina.neeley@musco.com

SCAN HERE TO TAKE YOUR FACILITY TO THE NEXT LEVEL OR VISIT PROMO.MUSCO.COM/NCPSMA

Parts & Service 24 hours a day, 7 days a week!
 Phone: (336) 697-2090 Fax: (336) 697-8247

LEWIS BOILER
 3127 Cedar Park Road
 Greensboro, NC 27405
www.lewisboiler.com
We Keep the Fires Burning!
We Carry ALL Makes/Models for steam, oil, gas, or hot water boilers

HONEYWELL CONTROLS	OIL FILTERS
HOFFMAN	TOPOG-E GASKETS
BELL & GOSSETT	FIREYE CONTROLS
BOILER SECTIONS	McDONNELL-MILLER
GOODWAY BRUSHES	REGULATORS, TRAPS
GLOBE, GATE, SOLENOID,	ITT GENERAL CONTROLS
BUTTERFLY, ETC. VALVES	IGNITORS/ELECTRODES
OIL NOZZLES	REFRACTORY MATERIAL
BURNERS & ACCESSORIES	PIPE FITTINGS

Eastern Convention DoubleTree Lodging Information

NCPSMA has a contract with DoubleTree by Hilton Atlantic Beach, North Carolina located at 2717 West Fort Macon Road, Atlantic Beach, North Carolina 28512.

When making reservations for your stay between September 24-30, 2023 remember the following:

- To receive group rates (Oceanview - \$149 per night and Oceanfront - \$199 per night), you must use the Group Code: **NCP**
- Reservations must be made before Thursday, September 6, 2023 to receive group rates.**
- Reservations can be made either by phone or online:
 - By Phone - (252) 240-1155
 - Online - https://www.hilton.com/en/hotels/oajtdtd-doubletree-atlantic-beach-oceanfront/?SEO_id=GMB-AM-ER-DH-OAJTDT&y_source=1_MTM3MjUyMi03MTUtbG9jYXRpb24ud2Vic2l0ZQ%3D%3D
- The room block will fill quickly so do not delay in making your reservations. Note: Once our room block has been met regular rates may apply.

If rooms at the DoubleTree fill up, you can find a list of other hotels in the area online at http://www.ncpsma.org/uploads/1/9/9/1/19910109/ec23_other_hotel_options_in_the_area.pdf



August 31 is International Overdose Awareness Day (IOAD)

Each year on August 31 we take time to observe International Overdose Awareness Day (IOAD). It is a day to remember those that have been lost to overdose by acknowledging the grief of the family and friends left behind and renew the commitment to end overdose and related harms.

The goals of International Overdose Awareness Day are:

- Provide an opportunity for people to publicly mourn loved ones.
- Send a strong message to people who use drugs and people in recovery that they are valued.
- Inform people around the world about the risk of drug overdose.
- Provide basic information on the range of support services that are available.
- Prevent and reduce drug-related harm by supporting evidence-based practice.

Recognizing an overdose can often be difficult. If you are not sure, it is best to treat the situation like an overdose because you could save a life. Call 911 immediately and do not leave the person alone.

Signs of an overdose may include:

- Small, constricted "pinpoint pupils"
- Falling asleep or loss of consciousness
- Slow, weak, or no breathing
- Choking or gurgling sounds
- Limp body

51st Annual NCPSMA Eastern Convention

Multiple Registration Form for Regular or Retired Regular Members

September 26-29, 2023 | Double Tree by Hilton | Atlantic Beach, North Carolina

IMPORTANT INFORMATION

- Regular or Retired Regular Members are those currently employed and/or retired from a North Carolina Public School System
 - o Regular or Retired Regular Members wishing to attend the conference must be current members of NCPSMA.
 - o You can register online at www.ncpsma.org if paying with debit/credit or by mailing this form in with your payment. o In order to expedite the Registration Check-in process, please be sure to pay all fees INCLUDING MEMBERSHIP prior to arrival to the Convention.
- Awards Banquet - NCPSMA welcomes members to bring family and friends, however **EACH PERSON is REQUIRED** to purchase a Banquet Ticket (\$10 each) **IN ADVANCE**.
 - o NCPSMA must provide DoubleTree a count for the Awards Banquet two (2) weeks prior to the event.
 - o You cannot purchase Banquet Tickets when you arrive for the conference.
- Boxed Lunches - On Wednesday and Thursday there will be a boxed lunch option for those who want to stay onsite for \$17 per lunch.
 - o NCPSMA must provide DoubleTree a count for the Boxed Lunches two (2) weeks prior to the event.
 - o You cannot purchase Boxed Lunches when you arrive for the conference.

PLEASE PRINT

NAME					
SCHOOL SYSTEM / LEA					
ADDRESS					
CITY			STATE	NC	ZIP
TELEPHONE					
EMAIL ADDRESS					

THIS FORM IS FOR CHECK PAYMENT ONLY

Conference Fees: Please circle/check all fees and items that apply and fill in blanks where appropriate.

ALL MEAL ITEMS MUST BE PURCHASED IN ADVANCE BEFORE SEPTEMBER 5, 2023

NAME	PRE-REGISTRATION Before 9/5/23	REGISTRATION After 9/5/23	MEMBERSHIP	WEDNESDAY (9/27/23) BOXED LUNCH	THURSDAY (9/28/23) BOXED LUNCH	BANQUET TICKET	TOTAL
	\$75	\$85	\$20	\$17 ___ Roast Beef ___ Ham & Swiss ___ Chicken Salad ___ Caprese Wrap	\$17 ___ Roast Beef ___ Ham & Swiss ___ Chicken Salad ___ Caprese Wrap	\$10	
	\$75	\$85	\$20	\$17 ___ Roast Beef ___ Ham & Swiss ___ Chicken Salad ___ Caprese Wrap	\$17 ___ Roast Beef ___ Ham & Swiss ___ Chicken Salad ___ Caprese Wrap	\$10	
	\$75	\$85	\$20	\$17 ___ Roast Beef ___ Ham & Swiss ___ Chicken Salad ___ Caprese Wrap	\$17 ___ Roast Beef ___ Ham & Swiss ___ Chicken Salad ___ Caprese Wrap	\$10	
	\$75	\$85	\$20	\$17 ___ Roast Beef ___ Ham & Swiss ___ Chicken Salad ___ Caprese Wrap	\$17 ___ Roast Beef ___ Ham & Swiss ___ Chicken Salad ___ Caprese Wrap	\$10	
	\$75	\$85	\$20	\$17 ___ Roast Beef ___ Ham & Swiss ___ Chicken Salad ___ Caprese Wrap	\$17 ___ Roast Beef ___ Ham & Swiss ___ Chicken Salad ___ Caprese Wrap	\$10	
							GRAND TOTAL

There will be no refunds after August 31, 2023.

- Boxed Lunches are served with an apple, potato chips, plastic ware & cookies/brownies.
- Roast Beef Sandwich with caramelized onion, horseradish aioli and sharp white cheddar
 - Ham and Swiss Sandwich with honey mustard, lettuce and tomato
 - Chicken Salad Croissant with lettuce and tomato
 - Caprese Wrap with spinach basil, buffalo mozzarella, tomato and balsamic glaze

Payment Information

Checks: Payable to NCPSMA and mail to NCPSMA, 224 Mulberry Street, Clyde, NC 28721

Credit/Debit Cards: Pay online at www.ncpsma.org. Click on the Convention Information Tab, then the Eastern Convention Tab and then the Regular Member Information Tab.

Credit Card fees will apply.

NCPSMA DISTRICT 7 GOLF TOURNAMENT

SAVE THE DATE

OCTOBER 13, 2023

Lunch at 12:00 pm - Golf at 1:00 pm

Brushy Mountain Golf Course

300 Golf Course Lane
Taylorsville, NC

For more information contact
Robert Hoyle or Kristie Gilbert with
Catawba County Schools at (828) 464-3562

Of the Year Awards

NCPSMA "Of the Year" Award Nominations

We need your help to honor some of the outstanding individuals in our profession. Is there someone in your District who goes above and beyond to promote our association and help others?

Here are a few qualities that made good "Of the Year" Award nominees:

- good leader
- set a good example for others
- value other people
- realize other people can help them and allow those people to help
- risk-takers who are willing to try new things
- have great strengths in decision making
- good at overcoming challenges and don't let little things get them down
- have a positive attitude
- flexible and adaptable
- learn from their mistakes

This list could go on and on but there is just one question you need to think about. When you think who has made a significant contribution to the advancement of North Carolina Public Schools Maintenance Who do you think of? We all know that one person that is so deserving.

So now is the time to nominate that person for the 2023 NCPSMA Maintenance Superintendent of the Year, Maintenance Director of the Year or Maintenance Employee of the Year.

These awards are sponsored annually by Saffelle, Inc. In 1987, Milt Saffelle with Saffelle, Inc. established the Maintenance Director of the Year Award and the Maintenance Employee of the Year Award. In 1996, the Superintendent of the Year Award was added.

"OF THE YEAR" AWARD GUIDELINES

Should you wish to nominate a candidate, please supply the information outlined below and return to the Milt Saffelle, Chairman of the NCPSMA Awards Committee by **Thursday, August 10, 2023.**

Superintendent of the Year Qualifications

- 1) Candidates may be superintendents, associate/assistant superintendents, who have the responsibilities for maintenance. They must be current members of NCPSMA.
- 2) Nominations must be made by an active member of NCPSMA. There should be a letter of nomination signed by the active member. Only one nominee, per category, may be submitted from each LEA. If more than one nominee, per category, from an individual LEA is submitted, same category nominations from said LEA will be **disqualified**. This decision was passed by the NCPSMA Advisory Council, May 2016.
- 3) Nominees must be from the NCPSMA **District** making the nomination.
- 4) The following data must be supplied for each candidate:
 - a) A photograph of the nominee must be included and placed on a separate sheet of paper.
 - b) A biographical sketch, preferably in narrative form and no more than two pages in length, including the nominee's achievements that have contributed to success in NCPSMA and other professional involvement.
 - c) No other information on nominee will be accepted.

Maintenance Director of the Year Qualifications

- 1) Maintenance Directors are defined as those who serve as **direct head** of the maintenance department.
- 2) Nominees for Supervisor of the Year awards must be currently employed as a maintenance person in an educational system in the state of North Carolina.
- 3) The nominee must have been an active member of the NCPSMA for the last five (5) **consecutive** years.
- 4) The nominee cannot be the current state president.
- 5) Nominations must be made by an active member of NCPSMA. There should be a letter of nomination signed by the active member. Only one nominee, per category, may be submitted from each LEA. If more than one nominee, per category, from an individual LEA is submitted, same category nominations from said LEA will be **disqualified**. This decision was passed by the NCPSMA Advisory Council, May 2016.
- 6) Nominees must be from the NCPSMA **District** making the nomination.
- 7) The following data must be supplied for each candidate:
 - a) A photograph of the nominee must be included and placed on a separate sheet of paper.
 - b) A biographical sketch, preferably in narrative form and no more than two pages in length, including the nominee's achievements that have contributed to success in NCPSMA and other professional involvement.
 - c) No other information on nominee will be accepted.

Maintenance Employee of the Year Qualifications

- 1) Maintenance Employees are defined as other members of maintenance staff.
- 2) Nominees for Employee of the Year awards must be currently employed as a maintenance person in an educational system in the state of North Carolina.
- 3) The nominee must have been an active member of the NCPSMA for the last five (5) **consecutive** years.
- 4) The nominee cannot be the current state president.
- 5) Nominations must be made by an active member of NCPSMA. There should be a letter of nomination signed by the active member. Only one nominee, per category, may be submitted from each LEA. If more than one nominee, per category, from an individual LEA is submitted, same category nominations from said LEA will be **disqualified**. This decision was passed by the NCPSMA Advisory Council, May 2016.
- 6) Nominees must be from the NCPSMA **District** making the nomination.
- 7) The following data must be supplied for each candidate:
 - a) A photograph of the nominee must be included and placed on a separate sheet of paper.
 - b) A biographical sketch, preferably in narrative form and no more than two pages in length, including the nominee's achievements that have contributed to success in NCPSMA and other professional involvement.
 - c) No other information on nominee will be accepted.

The "Of the Year" Awards Committee is comprised of the NCPSMA One-Year Advisory Council Members and Milt Saffelle, Chairman. The Chairman serves in an ex officio capacity and does not have voting privileges. In case of a tie the current State Vice President will have voting privileges. All nominations must be submitted no later than **Thursday, August 10, 2023** to: Milton Saffelle, Chairman, NCPSMA Awards Committee, PO Box 1499, Hillsborough, NC 27278.

51st Annual NCPSMA Eastern Convention

Individual Registration Form for Regular or Retired Regular Members

September 26-29, 2023 | Double Tree by Hilton | Atlantic Beach, North Carolina

IMPORTANT INFORMATION

- Regular or Retired Regular Members are those currently employed and/or retired from a North Carolina Public School System
 - o Regular or Retired Regular Members wishing to attend the conference must be current members of NCPSMA.
 - o You can register online at www.ncpsma.org if paying with debit/credit or by mailing this form in with your payment.
 - o In order to expedite the Registration Check-in process, please be sure to pay all fees INCLUDING MEMBERSHIP prior to arrival to the Convention.
- Awards Banquet - NCPSMA welcomes members to bring family and friends, however **EACH PERSON is REQUIRED** to purchase a Banquet Ticket (\$10 each) **IN ADVANCE**.
 - o NCPSMA must provide DoubleTree a count for the Awards Banquet two (2) weeks prior to the event.
 - o You cannot purchase Banquet Tickets when you arrive for the conference.
- Boxed Lunches - On Wednesday and Thursday there will be a boxed lunch option for those who want to stay onsite for \$17 per lunch.
 - o NCPSMA must provide DoubleTree a count for the Boxed Lunches two (2) weeks prior to the event.
 - o You cannot purchase Boxed Lunches when you arrive for the conference.

PLEASE PRINT

NAME				
SCHOOL SYSTEM / LEA				
ADDRESS				
CITY		STATE	NC	ZIP
TELEPHONE				
EMAIL ADDRESS				

THIS FORM IS FOR CHECK PAYMENT ONLY

Conference Fees: Please circle/check all fees and items that apply and fill in blanks where appropriate.
ALL MEAL ITEMS MUST BE PURCHASED IN ADVANCE BEFORE SEPTEMBER 5, 2023

DESCRIPTION	AMOUNT	TOTAL
PRE-REGISTRATION Before September 5, 2023	\$75.00	
REGISTRATION After September 5, 2023	\$85.00	
Membership Dues	\$20.00	
Wednesday (9/27/23) Boxed Lunch	\$17.00 <input type="checkbox"/> Roast Beef <input type="checkbox"/> Ham & Swiss <input type="checkbox"/> Chicken Salad <input type="checkbox"/> Caprese Wrap	
Thursday (9/28/23) Boxed Lunch	\$17.00 <input type="checkbox"/> Roast Beef <input type="checkbox"/> Ham & Swiss <input type="checkbox"/> Chicken Salad <input type="checkbox"/> Caprese Wrap	
BANQUET TICKET	Quantity _____ x \$10.00	
There will be no refunds after August 31, 2023.		
GRAND TOTAL		

Boxed Lunches are served with an apple, potato chips, plastic ware & cookies/brownies.

- Roast Beef Sandwich with caramelized onion, horseradish aioli and sharp white cheddar
- Ham and Swiss Sandwich with honey mustard, lettuce and tomato
- Chicken Salad Croissant with lettuce and tomato
- Caprese Wrap with spinach basil, buffalo mozzarella, tomato and balsamic glaze

Payment Information

Checks: Payable to NCPSMA and mail to NCPSMA, 224 Mulberry Street, Clyde, NC 28721
Credit/Debit Cards: Pay online at www.ncpsma.org. Click on the Convention Information Tab, then the Eastern Convention Tab and then the Regular Member Information Tab.
Credit Card fees will apply.

DISTRICT SEVEN GOLF TOURNAMENT

Annual Scholarship Golf Tournament

Friday, October 13, 2023

Brushy Mountain Golf Course, Taylorsville, NC

***Please register by September 23, 2023 if possible*

REGISTRATION OPEN TO THE PUBLIC (All are welcome) Maintenance personnel and directors, vendors, and the public are invited!

North Carolina Public School Maintenance Association District VII (consisting of 13 northeastern counties) is hosting their 22nd Annual Scholarship Golf Tournament! We encourage participation from each county to support this excellent educational opportunity for our well-deserving students!

Tournament Format:

- Limited to 25 Teams
- Captian's Choice: Four players per team
 - Players may make their own pairings.
- \$60 entry fee per player
 - Covers: green fees, carts, prizes, catered lunch, and two mulligans (one on the front and one on the back).
 - An additional two mulligans can be purchased for \$10.
- Lunch and Registration starts at 12 PM. Tee-off is at 1 PM!

Prizes & Information:

- Cash prizes for 1st and 2nd place and for closet to the pin and the longest drive.
- Snacks and soft drinks will be available throughout the tournament.

Hole Sponsorship & Donations:

- Hole sponsorship cost is \$100
 - Furnishes a sign on your hole with your company name and number if requested
- Tent Sponsorship cost is \$200
- Team Sponsorship cost is \$240
- Vendor donations needed for prizes and are greatly appreciated!

Please contact Robert Hoyle at 828.464.3562 with questions.!

We look forward to seeing everyone and having a great time of fun, fellowship, and golf!

Respectfully yours,

Jeff Adams, President, NCPSMA District VII



DISTRICT SEVEN GOLF TOURNAMENT SPONSORSHIP FORM

VENDOR NAME: _____

CONTACT NAME: _____

PHONE NUMBER: _____

Yes, we would like to help sponsor the District seven golf tournament by:

Hole Sponsorship \$100: _____

Tent Sponsorship \$200: _____

Team Sponsorship \$240: _____

Monetary Donations (Amount): _____

Door Prizes: _____

Raffle Item: _____

All sponsors will be recognized during the tournament and in the Maintenance Beacon by District Seven.

****Your help, dedications, and support are greatly appreciated!**

THANK YOU!!!

Accepted forms of payment are cash or check made payable to NCPSMA. Please mail, fax or email sponsorship form to:

Robert Hoyle
 PO Box 1010
 Newton, NC 28681
 Robert_hoyle@catawbасhools.net
 Phone: 828.464.3562 (office)

DISTRICT SEVEN GOLF TOURNAMENT TEAM SIGN UP FORM

PLAYER ONE NAME: _____

PLAYER TWO NAME: _____

PLAYER THREE NAME: _____

PLAYER FOUR NAME: _____

TEAM NAME: _____

TEAM CAPTIAN: _____

PHONE: _____ EMAIL: _____

PAYMENT: CASH _____ CHECK _____ AMOUNT _____ CHECK No. _____

*****Requesting pre-registration by September 23, 2023*****

Accepted forms of payment are cash or check made payable to NCPSMA. Please mail, fax or email sponsorship form to:

Robert Hoyle
 PO Box 1010
 Newton, NC 28681
 Robert_hoyle@catawbасhools.net

Eastern Convention Tentative Agenda

51st ANNUAL NCPSMA EASTERN CONVENTION/WORKSHOP

DoubleTree by Hilton / Atlantic Beach, NC

September 26-29, 2023

Tentative Agenda

TO OBTAIN CREDIT FOR CREDIT HOUR CLASSES YOU MUST ATTEND ALL CLASSES

**** REMINDER** CLASSES ARE OPEN TO EVERYONE - NOT JUST INDIVIDUALS NEEDING THEIR CEU'S**

Tuesday, September 26, 2023

2:00-7:00 Foyer	Early Registration
3:30-5:30 Pamlico	2024 Western Convention Planning Meeting (Planning Committee Members)
5:30-6:00 Prime	Planning Committee and Advisory Council Members Dinner
6:00-7:30 Pamlico	Advisory Council Meeting

Wednesday, September 27, 2023

6:00-5:00 Foyer	Registration
6:30-9:00 Foyer	Coffee Break and Biscuits
7:00-9:00 Pamlico/ Hatteras	Electrical (2 CEU's) <i>Presented by Josh West, Cabarrus County Building Inspector</i>
Cape Fear/ Cape Lookout	Locksmith License Renewal (2 CEU's) <i>Presented by Tammy Griffin and Scott Shipton, End User Specialist, ASSA ABLOY</i>
Onslow	Dual Water (2 CEU's) <i>Presented by Randall Jarrell, Wastewater Biologist/ Consultant/Contract Operator, Wastewater Management, LLC, Instructor for the NCDENR Operator's Certification Commissions</i>
Bogue Sound	Ornamental & Turf Pest Control (2 CEU's) <i>Presented by Tom Glasgow, County Extension Director/ Horticulture Agent, NC State University / NC Cooperative Extension - Craven County Center</i>
Atlantic	OSHA and OSHA Record Keeping <i>Presented by Randy Cranfill, Surry Insurance</i>
9:00-10:00 Atlantic	Opening Session and Business Session
10:00-12:00 Pamlico/ Hatteras	Electrical (2 CEU's) <i>Presented by Josh West, Cabarrus County Building Inspector</i>
Cape Fear/ Cape Lookout	Locksmith License Renewal (2 CEU's) <i>Presented by Tammy Griffin and Scott Shipton, End User Specialist, ASSA ABLOY</i>
Onslow	Dual Water (2 CEU's) <i>Presented by Randall Jarrell, Wastewater Biologist/ Consultant/Contract Operator, Wastewater Management, LLC, Instructor for the NCDENR Operator's Certification Commissions</i>
Bogue Sound	Ornamental & Turf Pest Control (2 CEU's) <i>Presented by Shawn Banks, County Extension Director and Extension Agent - Agriculture / Horticulture, NC State University / NC Cooperative Extension - Carteret County Center</i>
Atlantic	Google Workspace <i>Presented by Cumberland County Schools</i>
12:00-1:30	Lunch on Your Own or Boxed Lunch (MUST BE PURCHASED IN ADVANCE)
1:00 Brandywine Bay Golf Club	Annual Jay Palmer Memorial Scholarship Golf Tournament <i>Sponsored by Premier Supply, Inc.</i>
1:30-3:30 Pamlico/ Hatteras	Electrical (2 CEU's) <i>Presented by William "Al" Parris, Continuing Education, Examination and Enforcement Manager, NC Board of Examiners of Electrical Contractors</i>
Cape Fear/ Cape Lookout	Locksmith License Renewal (2 CEU's) <i>Presented by Tammy Griffin and Scott Shipton, End User Specialist, ASSA ABLOY</i>
Onslow	Dual Water (2 CEU's) <i>Presented by Randall Jarrell, Wastewater Biologist/ Consultant/Contract Operator, Wastewater Management, LLC, Instructor for the NCDENR Operator's Certification Commissions</i>
Bogue Sound	Beyond Certified PD: How Should We Train Our Facilities Departments? <i>Presented by Anthony J. Cox, PE, Hickory Public Schools</i>
1:30-2:30 Atlantic	Floor Care Basics <i>Presented by Edward Zgrabik, Vice President of North American Sales, Essential Industries</i>

2:30-3:30 Atlantic	Shelter in Place Lockdown Solutions <i>Presented by Barry Phillips, Regional Sales Director, Wesco</i>
3:30-5:30 Pamlico/ Hatteras	Electrical (2 CEU's) <i>Presented by William "Al" Parris, Continuing Education, Examination and Enforcement Manager, NC Board of Examiners of Electrical Contractors</i>
Cape Fear/ Cape Lookout	Locksmith License Renewal (2 CEU's) <i>Presented by Tammy Griffin and Scott Shipton, End User Specialist, ASSA ABLOY</i>
Onslow	Press Fittings in the School System <i>Presented by Andreas Adrian, Regional Technical Manager, Viega</i>
Bogue Sound	Developing Hand/Surface Hygiene Programs in the K-12 Market <i>Presented by Joe Hoff, Southeastern Public Section & K-12 Manager, GOJO and Mike Conley, State of NC Manager, GOJO</i>
Atlantic	Cost Management Strategies for Irrigation Systems <i>Presented by Andrew LaRowe, President, EduCon</i>

Thursday, September 28, 2023

7:00-5:00 Foyer	Registration
7:00-10:00	Coffee Break
8:00-9:00 Onslow	Spectator Seating: Code Compliance and Preventative Maintenance <i>Presented by Stephen Bishop, President and Owner, Seating Safety Solutions, Inc. and Jacob Lovings, Safety Specialist, Seating Safety Solutions, Inc.</i>
8:00-10:00 Bogue Sound	Structural Pest (2 CEU's) <i>Presented by Regan Daniels, NC State University</i>
9:00-10:00 Onslow	Care, Maintenance and Fire Code Compliance for Your Stage Curtains <i>Presented by Steve McKee, President, Premier Drapery Cleaning</i>
9:00-9:30 Atlantic	Exhibitor Display Selection
9:30-11:00 Atlantic	Exhibitor Display Setup
10:00-12:00 Bogue Sound	Structural Pest (2 CEU's) <i>Presented by Regan Daniels, NC State University</i>
10:00-11:00 Onslow	Director's Round Table Meeting
11:00-12:00 Atlantic	Superintendents & Directors Visit with Exhibitors
12:00-1:00	Lunch on Your Own or Boxed Lunch (MUST BE PURCHASED IN ADVANCE)
12:00-1:00 Prime	State Officers, Superintendents & Directors Luncheon
1:00-5:00 Atlantic	Visit with Exhibitors

Friday, September 29, 2023

8:00-4:00 Foyer	Registration
8:00-10:00 Atlantic	Breakfast and Visit with Exhibitors
10:00-10:30	Vendor Break-Out Session (for all Vendors participating in the conference)
10:30-12:00 Atlantic	Exhibitor Display Breakdown
10:00-12:00 Onslow	Condensing vs. Non-Condensing Boilers - Making the Right Choice <i>Presented by James P. "Jim" Farrell, Richard K. Hunter</i>
Bogue Sound	Irrigation and Landscaping (2 CEU's) <i>Presented by Site One</i>
12:00-2:30	Lunch on Your Own
12:00-2:30 Courtyard	Cornhole Tournament <i>Contestants will need to "Sign Up" at the Registration Desk with a \$5 Entry Fee - Includes a Boxed Lunch</i>
2:30-3:30 Bogue Sound	Irrigation and Landscaping (2 CEU's) <i>Presented by Site One</i>
Onslow	Building Enclosure Survey and Maintenance: What Owners Can Do to Maximize Their Facility Performance <i>Presented by Mike Phifer, Department Manager and Paul Bielicki, Senior Architect, Terracon</i>
Cape Fear/ Cape Lookout	Are Your Custodians One of the Most Important People In Your District? <i>Presented by Bob Bittner, Wakes County Schools (Retired), OperationsHERO</i>
6:00-Until Atlantic	Awards Banquet