

# THE MAINTENANCE BEACON

The Monthly Newsletter of the North Carolina Public School Maintenance Association

Volume 58, Number 8  
August 2021

## Contents

Deadly Mistakes .....	3
Western Convention .....	
Exhibitor Photos .....	4
District Three GT .....	6
Obituary .....	7
Belmont Middle School .....	7
Jay Palmer GT Announcement .....	8
Guidelines For Top Awards .....	9
Eastern Convention Reservation Information .....	9
Eastern Convention Agenda .....	10
Eastern Convention Registration Forms .....	11



**JOIN US FOR THE 49TH ANNUAL NCPSMA EASTERN CONVENTION**

## MESSAGE FROM PRESIDENT

Greetings,

As we begin a new school year, I would like to thank each of you for your continued support of NCPSMA.

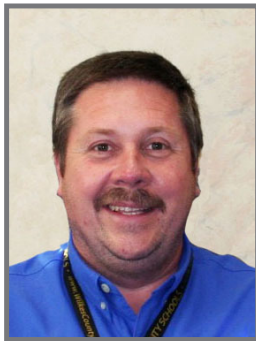

*Bergie Speaks*

It's been challenging over the last year and a half, to say the least. As you know we were not able to hold our Western or Eastern Conventions last year due to COVID-19. Thankfully we were able to hold the 2021 Western Convention and it was a success. Thanks to all our regular members who attended and to the vendors who participated for their continued support.

We are anticipating a successful 2021 Eastern Convention. I am looking forward to gathering with old friends again and making new friends. Together we will learn from our workshop presenters, vendors and from each other. From time to time, we share many of the same problems in the maintenance departments across the state. There is much to be learned from each other.

We appreciate all the financial support our vendors provide us and the opportunity to learn about new products and services they offer. Also, the conventions provide our vendors with the opportunity to entertain prospects for more business.

Just a reminder the NCPSMA Membership Year runs from July 1-June 30 each year. If you have not already renewed your membership, we encourage you to do so now. A membership application is provided in this issue of The Maintenance Beacon. If you have any questions concerning membership, please contact our NCPSMA Executive Director, Roxie Mack at 336.366.4939 or [roxiermack@gmail.com](mailto:roxiermack@gmail.com).

Let's continue to work together to support each other and our association. All involvement from our members, big or small, helps to continue the future success of NCPSMA.

I wish you a safe and prosperous 2021-2022 school year.

*Sincerely,*  
**Bergie Speaks, NCPSMA State President**

## Meetings and Events

### DISTRICT THREE MEETING

**August 5, 2021, 4PM** Red Oak Middle School  
3170 Red-Oak Battleboro Rd, Battleboro NC

For more information please contact Sue Farmer  
252.399.7823 or [sue.farmer@wilsonschooolsnc.net](mailto:sue.farmer@wilsonschooolsnc.net)

### NCPSMA EASTERN CONVENTION

**September 22-24, 2021**

Double Tree, Atlantic Beach, NC

For more information please contact Roxie Mack  
336.366.4939 or [roxiermack@gmail.com](mailto:roxiermack@gmail.com)

### DISTRICT THREE ANNUAL GOLF TOURNAMENT

**October 29, 2021 • Rain Date November 5, 2021**

Shotgun start at 1:00 PM • Wedgewood Golf Course, Wilson NC

For more information please contact Sue Farmer  
252.399.7823 or [sue.farmer@wilsonschooolsnc.net](mailto:sue.farmer@wilsonschooolsnc.net)

## INDEX OF ADVERTISERS

ACI Systems .....	7
ACR Supply Co. ....	3
Atlantic Coastal Supply, Inc. ....	9
Carolina Courtworks. ....	10
Davidson Sash & Door .....	4
D.H. Bruch Marketing, Inc. ....	4
Duro-Last Roofing .....	6
Floor Action .....	3
Green Air Environmental .....	3
Hardware Distributors.....	5
Hoffman & Hoffman .....	9
James M. Pleasants Co.....	9
Ken Staley Co., Inc.....	9
Lewis Boiler Supply .....	6
Loman Garrett.....	3
Matt Marshall & Co.....	7
Pinnacle Dryer Corp.....	5
Reece, Noland & McElrath.....	9
Richard K. Hunter & Co.....	4
Royalwood .....	4
Saffelle, Inc.....	6
Seating Safety Solutions.....	7
Seven Oaks Doors & Hardware .....	9
Seven Oaks Supply Co. ....	5
Sky Enterprises.....	9
The Blind Butler/Premier Drapery.....	3
The Cook & Boardman Group .....	2
WC Rouse .....	3

## INTRODUCTION TO WATER SOURCE HEAT PUMP SYSTEMS PART THREE: BASIC OPERATION

*By Chad Edmondson*

How does a water source heat pump (WSHP) work?

WSHPs operate similarly to traditional air source heat pumps (ASHPs) in that they transfer heat rather than creating it from a combustible fuel. Both incorporate a

*continued on page 3*

## MEETING DATES

The districts of NCPSMA meet twice yearly.

### District 1

January, July

### District 2

January, July

Pres. Ronald Moore

Phone: 910.296.1875

### District 3

February, August

Pres. Mark Letchworth

Phone: 252.399.7822

### District 4

February, October

Pres. Donna Fields

Phone: 910.678.2565

### District 5

March, September

Pres. Justin Dyson

Phone: 336.909.2280

### District 6

April, October

Pres. Chris Adkins

Phone: 980.343.4526

### District 7

May, November

Pres. Raymond Bowles

Phone: 336.751.1991

### District 8

March, November

V. Pres. Jason Kelly

Phone: 828.456.2402

### Meeting Dates & Locations

Should be sent to The Maintenance Beacon two months in advance for publication.

### Deadlines

Publication deadline for articles and advertisements is first day of the month prior to month of publication.



## PROUDLY SUPPORTING NCPSMA MEMBERS

We're your premier provider of architectural doors and frames, door hardware and related building specialty products as well as complete system integration services including: physical security, enterprise networking, low voltage cabling and more!

### HELPING TO MAINTAIN NORTH CAROLINA'S SCHOOLS SINCE 1955

The Cook & Boardman Group of companies is your premier provider of architectural doors and frames, door hardware, related building specialty products, electronic access control as well as complete systems integration and information technology services. With six convenient locations across the Tar Heel State, we're uniquely positioned to provide the best solutions for educational facilities. Allow us to offer you:

- Assessments
- Value engineering
- Specification review
- Project management
- Fire and life safety code compliance
- Installation, maintenance and service
- Product support/warranty management

To eliminate procurement headaches, choose our team to act as your single source for new construction and remodeling projects, as well as for any IT implementation. Contact your local branch to get started today!

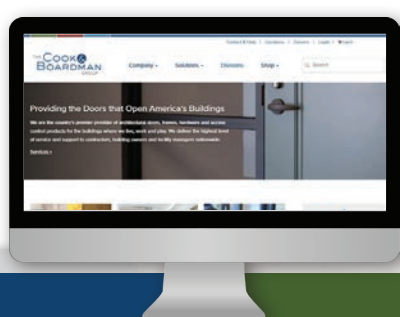
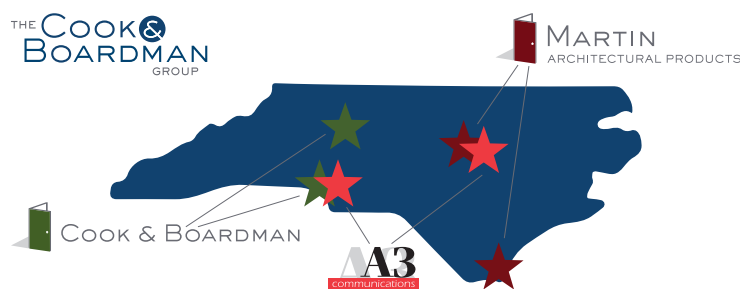

Visit [www.COOKANDBOARDMAN.com](http://www.COOKANDBOARDMAN.com) to learn more about our group, find helpful resources and to place product orders.

### MEET YOUR LOCAL COOK & BOARDMAN TEAMS



#### A3 Communications

Construction Divisions: 27 & 28

With offices in Charlotte and Raleigh, A3 Communications is one of the nation's leading systems integrators. Purchase both your IT and physical security needs from one of their many state contracts!

Charlotte Office: Matt Whitfield | (704) 956-3908  
Raleigh Office: Greg Mooror | (803) 269-9222



#### COOK & BOARDMAN



#### Cook & Boardman

Construction Divisions: 8 & 10

With offices in Charlotte and Winston-Salem, Cook & Boardman has provided architectural doors, frames and hardware across the state since 1955. Counter sales, pre-installation, fabrication, installation and service available!

Charlotte Office: Ron Hill | (704) 936-6508  
Winston-Salem Office: Vernon Spence | (336) 462-1829



#### MARTIN ARCHITECTURAL PRODUCTS



#### Martin Architectural Products

Construction Divisions: 8 & 10

With offices in Cary and Wilmington, Martin Architectural Products is the leading provider of architectural doors, frames and hardware in eastern North Carolina. Counter sales, installation and service available!

Cary Office: Ira Garner | (919) 868-6593  
Wilmington Office: Kyle Praeuner | (402) 841-1345

# DEADLY MISTAKES

**Fatal Event:** A 30-year-old man was fatally injured and a second employee was hospitalized when they were struck by an uncontrolled vehicle on a major highway while providing traffic control services.

**Investigative Findings:** A traffic control service company was hired and was responsible for the setup, maintenance and break down of the traffic control devices to alert motorists to a closure and detour around a work zone on a four-lane divided highway, with a posted speed limit of 65 mph. The company was paid for the use of the equipment, including barrels, cones, signs, and message boards, and for the labor expenses of two employees who set up, maintained, and removed the road closure signage.

The lane closure was set up and activated at 9 p.m. and removed every day prior to 6 a.m. to allow for the free flow of traffic along the highway. Three off-duty police officers with patrol cars were on-site stationed at the initial closure barricade and along the detour route during the closure. There were three sets of temporary road signs on each side of the highway. One employee would stand up the right side signs while the other employee would walk across the live lanes of the highway to stand up the left side signs. A total of 12 trips were made across the live travel lanes daily to accomplish this task.

The accident event occurred just prior to 5 a.m. as the employees were removing the last temporary sign along the east side of the highway. The lane closure was already removed and all signage had been placed in storage along the roadway. The detour was deactivated and the police officers had been released from their assigned stations.

The employees had each parked on the right shoulder of the road, with two tires in the grass and their vehicles about 30-feet apart. This placed the driver side of the vehicle next to the travel lane. Vehicle-mounted strobe lights were flashing on their respective trucks as they walked back to their vehicles to head home. A Jeep Cherokee was traveling north along the highway at an estimated speed of 80 mph when it struck the first pickup truck just behind the driver's side door but kept moving forward and struck the two employees. The Jeep continued along the paved shoulder of the highway until it veered off to the right, traveling down a grass embankment, over a ditch, through a fence, and finally coming to rest on a service road.

**Discussion:** The traffic control plan did not provide the safest environment for the employees during the most dangerous part of their workday activities. The *continued on page 5*

# INTRODUCTION TO WATER SOURCE HEAT PUMP SYSTEMS PART THREE: BASIC OPERATION

*continued from page 1*

refrigeration cycle to facilitate heat transfer and both include a valve to reverse the cycle, depending on whether the unit is in heating or cooling mode. The primary distinction between WSHPs and ASHPs is that WSHPs absorb and extract heat from a water loop while ASHPs absorb and extract heat from the outdoor air.

Typically, in commercial applications, multiple WSHPs are connected to a common water loop which is maintained within an operating temperature range of 60°F to 90°F. When more zones need heating than cooling, the loop temperature drops (approaching 60°F) and the boiler may be activated to make up the heat deficit, thus returning the loop to its operating range. When more zones need cooling than heating, the loop temperature rises (approaching 90°F) and the cooling tower may be activated to reject the surplus heat.

*continued on page 6*

premierdraperycleaning.com  
O: (910) 794-1664



**Premier DRAPERY CLEANING**

**All the world's a stage and we're here to clean it!™**  
Stage Draperies • Acoustical Panels • Upholstery • Flameproofing

The Southeast's premier service for on-site cleaning, flame retardant application, and certification



**FACULTY & STUDENTS DESERVE A HIGH-PERFORMANCE ENVIRONMENT**  
INCREASED INDOOR AIR QUALITY, DECREASED ABSENTEEISM & IMPROVED PERFORMANCE

Air Handler Units are designed to cycle air throughout your institution's facilities while maintaining a steady, even temperature and cleaning the air. If your HVAC system is contaminated with mold and toxins, you're doing nothing but spreading germs and illness, potentially hurting your students and staff. Green Air's targeted process restores your units to like-new condition without invading your faculty's space or classrooms.

- ✔ Toxin-free air.
- ✔ Help your collegiate athletes perform at their best.
- ✔ Significantly increases productivity levels.
- ✔ Reduces student absenteeism and facility liability issues.
- ✔ Environmentally friendly process and zero chemical residue.
- ✔ No coil corrosion like traditional, chemical laden cleaning methods.
- ✔ Eliminates contaminants resulting in healthier air quality and healthier staff and students.
- ✔ Immediate increase in efficiency and lower energy bills.
- ✔ **LIVE, BREATHE & SAVE GREEN.**

 1.800.789.3734  
GreenAirEnv.com 

**PARTNER WITH ACR SUPPLY FOR YOUR LG VRF/DFS NEEDS**



ACR  
SUPPLY CO.



LG  
Life's Good







- Factory Trained Sales Engineers
- Factory Trained Technical support
- ACR Training Facility
- Installation Site Visits
- LG Excellence Program
- Job Site analysis

**INSIDE SALES 336-217-0090 | 336-217-9222**  
SCAN QR CODE FOR MORE INFORMATION FROM LG





**Bard**  
SINCE 1914  
CLIMATE CONTROL SOLUTIONS

**Wall Mount Equipment**  
*and Parts!*



50% Quieter

20% More Efficient

And ...  
"Service Simple"



**Loman Garrett**  
Precision Climate Management  
**800-669-1761**



**W.C. ROUSE & SON**  
BOILER ROOM EQUIPMENT & SERVICES

*Servicing all boiler brands,*  
**24 hours a day, 7 days a week**

**Our purpose is simple: To leave every boiler room better than we found it.**

**Offering:**

- 24/7 Service
- Parts, for all Boiler Brands
- Boilers, of All Constructions
- Boiler Ancillary Equipment
- New, Used and Rental Equipment



Greensboro, NC  
336-299-3035

Charlotte, NC  
704-583-4005

sales@wcrouse.com  
wcrouse.com

Wilmington, NC  
336-299-3035

Columbia, SC  
803-765-1477

# Floor Action

*Serving your area for over 30 years*

We install, repair and refinish all types of floors. Bleacher repair and inspections. Fire and water damage restorations. Power volleyball inserts and installation.

**Patrick Morningstar, Owner**  
**Josh Walton, Sales**

Toll Free 800.745.6116      Fax 252.291.8042  
Local 252.291.6116      scsbyflooraction@gmail.com

**WALKWAY COVERS** **REPLACEMENT WINDOWS**



Phone 336-249-0276 Fax 336-249-7750

**Davidson Sash & Door, Inc.**  
1358 Piedmont Drive, Lexington, N.C. 27295-1952

**WEIL-McLAIN**  
Without compromise | 1881

Weil-McLain redefines heating all over again.



**Richard K. Hunter & Co.**  
Manufacturer's Agent  
712 West Lexington Ave., Suite 201, High Point, NC 27262  
PO Box 5105  
800-535-4140 / 336-288-7703 (fax)  
Call your distributor or visit [www.weil-mclain.com](http://www.weil-mclain.com) to learn more.

**BRUCH**  
MARKETING, INC.

**Door & Hardware Representatives**  
(704) 588-5214  
352 Crompton St.  
Charlotte, NC 28273

**ABH Manufacturing**  
**Dormakaba, USA**

- Best Locks, Closers, Hinges & Exit Devices (PHI)
- dormakaba Closers, Locks, Exit Devices & Commercial Hardware

**FRP Architectural Doors**  
**National Guard Products**  
**Phoenix Door Systems**  
**Security Door Controls**  
**Trimco Hardware**

*Providing Great Service for 59 years*

**Royalwood Associates**  
Specialty Flooring

Serving North Carolina, South Carolina & Virginia for over three decades.

[www.royalwood.us](http://www.royalwood.us)  
919-957-3006



Specializing in Wood & Synthetic Flooring Services for Public & Private Schools:

- Annual Screening & Recoating
- Sanding & Refinishing
- Court line & logo painting, staining, tinting & design
- Resurfacing (pad & pour)
- Installation & design of new wood & synthetic floors

Gymnasiums, Weight Rooms, Dance Rooms, Stages, Running Tracks, Multi-purpose Rooms, etc.

For more information contact Greg Serpas at 336-707-9976 or [greg@royalwood.us](mailto:greg@royalwood.us)

# 13<sup>TH</sup> ANNUAL WESTERN CONVENTION EXHIBITOR PHOTOS



**13<sup>TH</sup> ANNUAL WESTERN CONVENTION EXHIBITOR PHOTOS**



**DEADLY MISTAKES**

*continued from page 3*

employees were exposed to high speed traffic when crossing the live lanes of the highway to set up and take down signs along the left side of the north bound highway. It is an accepted industry standard that employees do not walk across lanes of traffic that are posted over 35 mph.

When it is necessary for employees to cross the highway to put up or take down signage, they must be protected. Protection may be attained by a Truck Mounted Attenuator (TMA), or crash cushion vehicle, or a slow-moving operation caravan in addition to high visibility law enforcement vehicles. This arrangement would form a "rolling roadblock" to keep all lanes of traffic moving at a safer speed for a short amount of time while the specific operation is occurring. The work zone specialist or employee would drive their strobe-mounted vehicle in front of the caravan and stop and get in and out of their vehicles safely to install or take down the left lane signs. The caravan or TMA and police vehicles would provide protection for the employees.

The employer had not developed a program which addressed the proper techniques to be used to set up and take down left side signage to create the safest possible situation for their employees to work.

*continued on page 6*

**MEMBERSHIP APPLICATION**

Please mail this form with your dues payment (\$20) to:  
NCPSMA, 630 Adams Ridge Road, State Road, NC 28676-9536

Name \_\_\_\_\_

Address \_\_\_\_\_

City \_\_\_\_\_ State \_\_\_\_\_ Zip Code \_\_\_\_\_

Telephone (\_\_\_\_) \_\_\_\_ - \_\_\_\_\_ Email \_\_\_\_\_

School System \_\_\_\_\_ District \_\_\_\_\_

Company \_\_\_\_\_

(Individual memberships only-no 'company' memberships)

If you would like a reminder sent to your e-mail each month when the latest edition of the Maintenance Beacon is available online, please check below.

\_\_\_\_\_ Yes I would like a reminder sent.

**THE MAINTENANCE BEACON**

**Executive Director:** Roxie Mack  
**Phone:** 336.366.4939  
**Fax:** 336.366.4938  
**E-Mail:** roxiermack@gmail.com  
**Website:** www.ncpsma.org

The Maintenance Beacon is the monthly publication of the North Carolina Public School Maintenance Association. Advertising, editorial material, memberships and subscriptions are handled through the office of the Executive Director, 630 Adams Ridge Road, State Road, NC 28676-9536.

NCPSMA does not guarantee, warranty or defend the use of any products or services of those who sponsor, advertise or contribute articles in The Maintenance Beacon.

**Officers of the Association**

<b>President</b>	Bergie Speaks	336.667.2021
<b>Vice President</b>	David Martin	704.658.2630
<b>Secretary</b>	Kristie Payne	828.456.2402
<b>Liaison Officer</b>	Mark Letchworth	252.399.7822

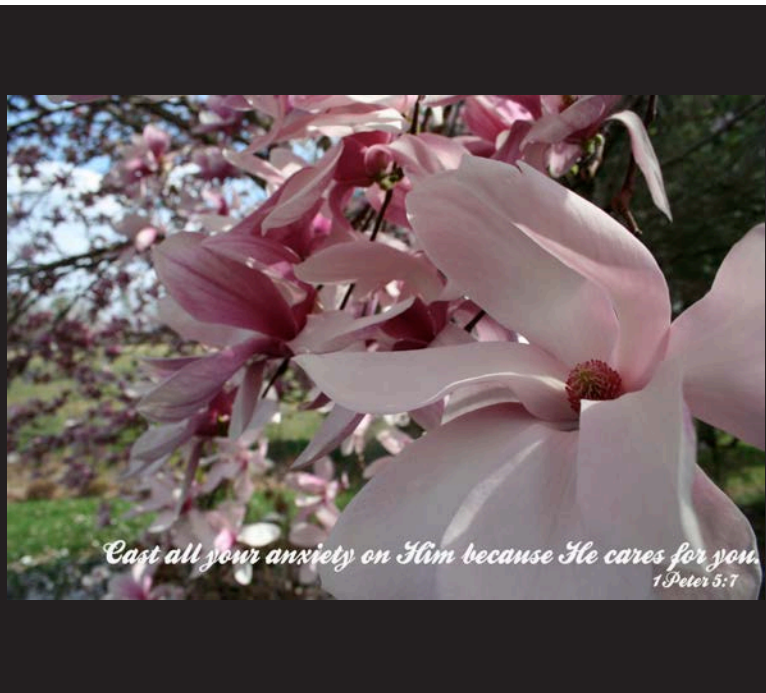

**PINNACLE HAND DRYERS**  
Call 800-943-7937 Aberdeen, NC

Vandal-Resistant  
Automatic & Quiet  
Low Maintenance  
Made in USA!

[www.PinnacleDryer.com](http://www.PinnacleDryer.com)

**Hardware Distributors Inc.**  
WHOLESALE DISTRIBUTOR FOR  
MAJOR BRANDS OF

**Builders Hardware—**  
Architectural Wood Doors, CECO Hollow Metal  
Doors & Frames Washroom Accessories &  
Toilet Partitions

PO Box 16847 216 Industrial Ave.  
Greensboro, NC 27406 1-800-632-1324

**Seven Oaks**  
SUPPLY COMPANY  
CUTTING-EDGE CLEANING CONCEPTS

**YOUR #1 SOURCE FOR...**

- CUTTING-EDGE FLOOR CARE PRODUCTS
- RESTROOM CLEANING PROGRAMS
- ODOR CONTROL
- FLOOR CLEANING EQUIPMENT
- PAPER PRODUCTS & DISPENSERS

800-230-7460  
OAKBORO, NC

**DISTRICT THREE GOLF TOURNAMENT  
SAVE THE DATE**

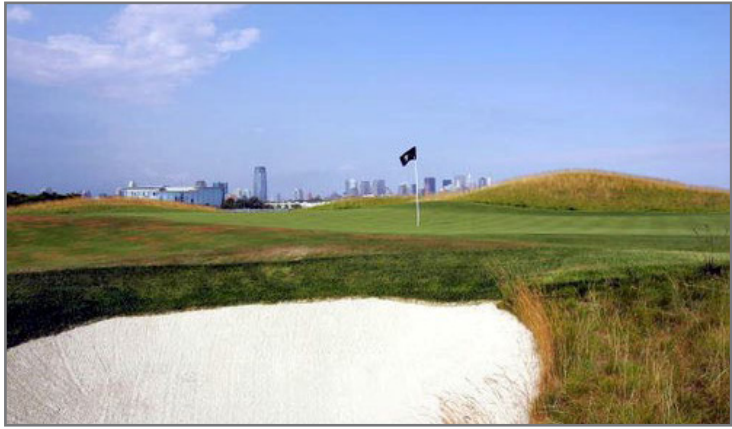

**WEDGEWOOD PUBLIC GOLF COURSE  
WILSON, NC  
FRIDAY, OCTOBER 29, 2021  
RAIN DATE - FRIDAY, NOVEMBER 5, 2021  
1:00 PM SHOTGUN START**

**INTRODUCTION TO WATER  
SOURCE HEAT PUMP SYSTEMS  
PART THREE: BASIC OPERATION**

*continued from page 3*

Because buildings with multiple zones encounter peak heating and cooling demands at different times during the day, individual heat pumps usually have capacity to spare. So, boiler or chiller operation may only be necessary during peak heating and cooling seasons.

**WSHP Refrigeration Cycle**

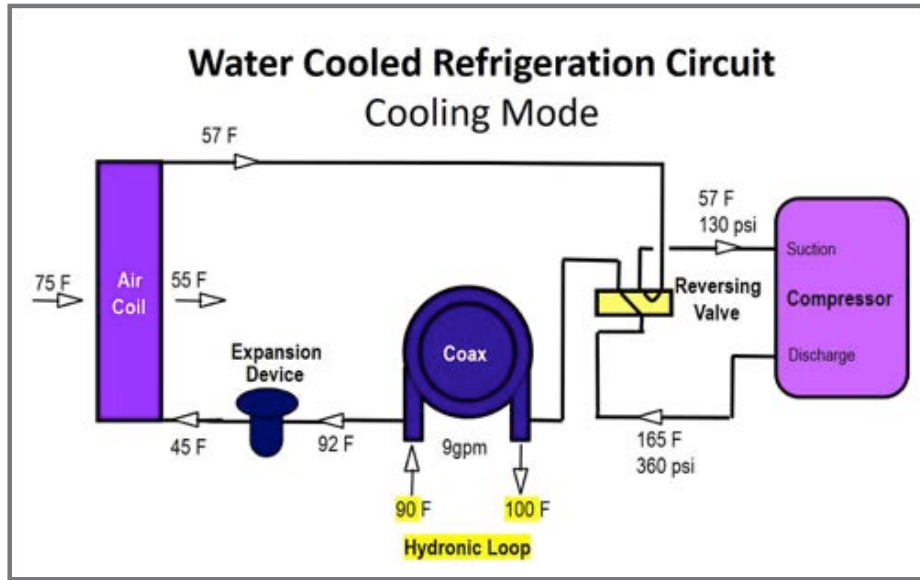

The only “complicated” part of a WSHP is the refrigeration cycle, but of course the same could be said of any heating or cooling equipment that relies on refrigerant, including your refrigerator.

WSHPs include two heat exchangers, a refrigerant-to-water heat exchanger and a refrigerant-to-air heat exchanger. The water side of the refrigerant-to-water heat exchanger is fed from the central hydronic loop. In cooling mode this heat exchanger acts as the condenser while the refrigerant-to-air heat exchanger acts as an evaporator.

When the WSHP is operating in cooling mode, heat is extracted from the hot return (building) air in the refrigerant-to-air coil through evaporation of the refrigerant. Meanwhile, hot gas from the compressor discharger is directed into the refrigerant-to-water heat exchanger where the hot gas condenses into liquid, giving up its heat to the colder loop water as it passes through the heat exchanger. Liquid refrigerant then passes through a metering device situated between the heat exchanger and the refrigerant-to-air heat exchanger (coil) where it evaporates, resulting in a drop in temperature on the air side. This cooler air is pushed into the space by a blower.

In heating mode, the process is simply reversed by way of a reversing valve that sits between the compressor and the refrigerant-to-water heat exchanger.

**Water Loop Lightens the Load on the WSHP**

Many WSHP systems provide simultaneous heating and cooling throughout most of the year. This is when a WSHP is operating at its most efficient, recovering and redistributing heating and cooling without the help of a chiller or boiler.

This is what makes WSHPs so efficient. Since the “give and take” of Btus between the building zones and the water loop makes it easy to keep the loop temperature between 60°F and 90°F with little or no help from the boiler or chiller, it is incredibly efficient. After all, if it is 20°F outside, it is a lot easier to heat a building by extracting Btus from 70°F water than from 20°F air. That’s less work (refrigeration cycling) that the heat pump has to do!

Reprinted by permission, James M. Pleasants Company

**DEADLY MISTAKES**

*continued from page 5*

**Recommendations:** Every work zone should have a traffic control plan in place that considers all dangers that could affect employees and motorists. Proper set up of work zones is critical for the safety of employees and motorists. Signs, cones and other devices are used to alert or warn motorists and guide them away from the work area. A work zone protects the road-side work area. Employees must be as visible as possible wearing reflective vests and helmets. Their vehicles need to have strobe lights and flashers to make them obvious to other drivers on the road.

A traffic management plan is usually required to outline the traffic hazards and specify the measures needed for traffic control. The traffic management plan should include:

*continued on page 7*

**Duro-Last®; the most water, wind and worry-resistant roof in the business.**

Duro-Last’s industry leading warranties are supported by prefabrication of roof panels and membrane accessories in a factory quality controlled environment. This eliminates up to 85% of field welding. Our highly trained technical field team inspects the field welded seams. Once you put a Duro-Last roof on, you can put it out of your mind.

**Edge-to-Edge & Deck-to-Sky™**

Bill Paynter 919-265-9045 Eastern NC	Jim English 980-875-8187 Western NC
--	---

Visit [duro-last.com](http://duro-last.com) or call to find out more.

**Parts & Service 24 hours a day, 7 days a week!**  
Phone: (336) 697-2090 Fax: (336) 697-8247

**LEWIS BOILER**  
3127 Cedar Park Road  
Greensboro, NC 27405  
[www.lewisboiler.com](http://www.lewisboiler.com)

**We Keep the Fires Burning!**  
**We Carry ALL Makes/Models for steam, oil, gas, or hot water boilers**

HONEYWELL CONTROLS	OIL FILTERS
HOFFMAN	TOPOG-E GASKETS
BELL & GOSSETT	FIREYE CONTROLS
BOILER SECTIONS	MCDONNELL-MILLER
GOODWAY BRUSHES	REGULATORS, TRAPS
GLOBE, GATE, SOLENOID, BUTTERFLY, ETC. VALVES	ITT GENERAL CONTROLS
OIL NOZZLES	IGNITORS/ELECTRODES
BURNERS & ACCESSORIES	REFRACTORY MATERIAL
	PIPE FITTINGS

**Saffelle, Inc.**  
SANITARY/MAINTENANCE/EQUIPMENT & SUPPLIES  
“Partnering with a Passion”  
**1-800-672-4525**  
GREEN EARTH  
[www.saffelle.com](http://www.saffelle.com)

**KEEP CALM & WASH YOUR HANDS**

# DEADLY MISTAKES

*continued from page 6*

- N The hazards related to the vehicle traffic.
- N Written procedures for setup, maintenance and removal of the work zone.
- N Roles and responsibilities in setting up, maintaining, inspecting and removing the work zone.
- N The layout of the work zone, including any changes as the work progresses.
- N The maximum speed allowed for vehicles throughout the work zone.
- N Types of signaling or traffic control devices to be used and their locations.
- N Management of any hazards created by the road work.
- N A communication strategy to inform the public in advance, where possible, about road work and temporary traffic diversion.
- N What procedures to follow in case of an incident.

*Reprinted by Permission, NC Labor Ledger, May/June 2021 Edition*

# OBITUARY

## EDDIE WILMOTH



Mr. Eddie Wayne Wilmoth, 67, of Dobson, NC passed away on Monday June 21, 2021, in Cabarrus County North Carolina. He was born in Surry County on October 5, 1953, to Wayne and Edna Wilmoth. He was a member of Salem Fork Christian Church.

Surviving is his wife Mrs. Debbie Simmons Wilmoth; sons and daughters-in-law, Andrew and Carmen Wilmoth, Edward Weslee and Andrea Wilmoth, Marcus and Mary Ann Wilmoth; grandchildren Brianna, Allison, Brody, Tess, Jeryd, Tayton, Jonah; sister and brother-in-law, Cheryl and Robert Schwab; brother and sister-in-law, Sam and Amanda Wilmoth; nephews, Eric, Jake, Noah Wilmoth.

A funeral service was held Friday, June 25, 2021, at Salem Fork Christian Church. Rev. Austin Caviness and Rev. Mark Reece, Jr officiated. The family has requested in lieu of flowers, memorials be made to Salem Fork Christian Church 2490 Zephyr Rd. Dobson, NC 27017 or to the Surry County Parks and Recreation 118 Hamby Rd. Dobson, NC 27017.

Eddie was the Founder and President of NWCD Inc. (Northwestern Carolina Distributors). He very supportive of NCPsMA. He supported the Eastern Conventions and District Seven Meetings and Fundraisers. For many years he ran an advertisement in The Maintenance Beacon.

Eddie was instrumental in the development of Fisher River Park and Surry County Sports Hall of Fame. He was one of the founders of Dobson Youth Basketball and served as the Western Commissioner of AAU Boys' Basketball in North Carolina. He was on the Surry County Parks and Recreation Advisory Commission and a Surry Community College Foundation member. Eddie was a former Head Basketball Coach for Surry Community College. He served on the Board of Director for Grande Shores Ocean Resort and was the founder and volunteer director of Dobson Coach Pitch baseball.

His family would like to thank all the friends and customers of NWCD for their support over the past 35 plus years. You are too numerous to name individually. Eddie also would like you to seek a personal relationship with Jesus and find a church home if you don't currently have one, he in the last days expressed his love for everyone he met and would like to see you again someday.

# LABOR COMMISSIONER VISIT

*By Natalie Bouchard, Public Information Officer*

Labor Commissioner Josh Dobson visited Belmont Middle School in Belmont on Monday, April 12, to celebrate the successful completion of the construction phase of the new 155,000 square foot school. He met with officials from the Gaston County school system, Beam Construction Co. and LS3P Associates, the architectural design company for the project, during a walk-through of the campus after the project's completion.

The construction phase of the \$33.54 million project spanned two years and Beam Construction, the general contractor, reported no lost time workplace injuries of employees. This included over 80 subcontractors, vendors and suppliers that were involved in the project.

"We always hope that any project results in zero injuries or accidents," Labor Commissioner Josh Dobson said. "And with a project of this scale, that's not always a guarantee. Beam Construction demonstrates exceptional care when it comes to the safety and health of its employees and all those involved in the work to build this new school. That is not only something to celebrate, it is something to replicate so that we can ultimately lower workplace injuries, illnesses and fatalities in workplaces throughout North Carolina."

Beam Construction Co. was recognized last year by the N.C. Department of Labor for earning its second consecutive year gold award under the NCDOL Safety Awards Program and the company is slated to receive its third consecutive gold award in 2021. Companies that receive safety awards must be free of fatal workplace accidents at the site for which the awards are given to be eligible. Gold awards are based on DART rates that are at least 50% below the statewide rate for its industry. The rate includes cases of days away from work, restricted activity or job transfer.

"As a district, we pride ourselves on school safety," said Dr. Jeff Booker, superintendent of Gaston County Schools. "If you look at the largest urban districts in North Carolina, we are the No. 1 district for safety. We're talking student safety. Worker safety runs hand in hand with that."

*Reprinted by Permission, NC Labor Ledger, May/June 2021 Edition*



**DON'T REPLACE IT... RESTORE IT!**



<p><b>WE OFFER:</b></p> <ul style="list-style-type: none"> <li>• Cost effective installation</li> <li>• Leak proof warranties</li> <li>• Seamless roof systems</li> <li>• Eco-friendly materials</li> <li>• Energy Star products</li> </ul>	<p><b>ADHERES TO:</b></p> <ul style="list-style-type: none"> <li>• Modified Bitumen</li> <li>• Single-Ply (TPO &amp; EPDM)</li> <li>• Metal Roof panels</li> <li>• Smooth Built-Up-Roof</li> <li>• Spray Foam</li> </ul>
---	--

(888) 233-5997  
Greensboro, NC
www.roofsbyaci.com
@RoofsbyACI  
f i o t t



**SEATING SAFETY SOLUTIONS, INC.**

The Carolinas' Largest Factory Backed Bleacher Service and Repair Company

- Indoor/Outdoor Bleachers
- Grandstands
- Auditorium Seating
- Arena Seating
- Lecture Seating
- Basketball Backstops

(336)622-1678 • www.seatingsafetysolutions.com



**BOILER-BURNER / SALES & SERVICE**

## MATT MARSHALL & CO.

INDUSTRIAL EQUIPMENT & SUPPLIES  
GREENSBORO, N.C.

PH: 336-292-8477 FAX: 336-299-0249  
1-800-632-1274  
Email: Sales@MMCO.net

*"Call us for your boiler room supplies."*

- ASCO "REDHAT" VALVES
- BACHARACH
- BELL & GOSSETT
- CONBRACO
- ELECTRODES
- FIREYE
- GAUGES
- HONEYWELL / RM 7800

- ITT GENERAL CONTROLS
- MAXITROL
- McDONNELL-MILLER
- SPIROTHERM
- THERMOMETERS
- TOPOG-E GASKETS
- TRANSFORMERS
- WATTS VALVES

WWW.MMCO.NET      Email: Sales@MMCO.net

★ *Serving Industry Since 1954* ★

**"Steam Is Our Specialty"**

## 20<sup>TH</sup> ANNUAL JAY PALMER SCHOLARSHIP GOLF TOURNAMENT ANNOUNCEMENT

This Golf Tournament is the only fund raiser we have had since our formation in 1990 other than a hat auction in 1991 (the hat collection of James B. (Jay) Palmer, Jr.) during the NCPSMA annual meeting that year.

Prior to 20 years ago our only means of fund raising was thru donations from people that knew Jay, NCPSMA Districts, vendors, family members, and friends.

During the first Golf Tournament we were able to raise over \$8,000.00. Handi-Clean Products, hole sponsors, and players made the tournament a success. Over the last 19 years Handi-Clean has been sold, sponsors and players have been on the decline. Premier Supply, Inc has agreed to be our new sponsor. With them and our Palmer family we ask that you help us to revive the tournament. The future leaders of our communities, that our scholarship fund supports, will appreciate it as well.

PLEASE HELP US TO MAKE THIS A GREAT TOURNAMENT!!

Sincerely Yours, Premier Supply Company  
Jay Palmer Family

P.S. "THANK YOU FOR YOUR CONSIDERATION!"

## 20<sup>TH</sup> ANNUAL JAY PALMER SCHOLARSHIP GOLF TOURNAMENT HOLE SPONSORSHIP

The tournament will be played during the fall conference at Atlantic Beach, NC on Thursday, September 23, 2021 at the Star Hill Golf Club.

### SPONSORSHIPS AVAILABLE

**Check whichever you like and complete the information at the bottom of the page**

1. **GOLD** - \$500.00 - GOLD SPONSOR  
sign with your name on the tee of one hole.  
\_\_\_\_\_ YES, my check is enclosed, send before September 17<sup>th</sup>.
2. **SILVER** - \$250.00 - SILVER SPONSOR  
sign with your name on one hole.  
\_\_\_\_\_ YES, my check is enclosed, send before September 17<sup>th</sup>.
3. **BRONZE** - \$125.00 - BRONZE SPONSOR sign with your name on one hole.  
\_\_\_\_\_ YES, my check is enclosed, send before September 17<sup>th</sup>.
4. **HOLE SPONSORS** - \$100.00 each gets a sign on the tee box of a hole.  
\_\_\_\_\_ YES, my check is enclosed, send before September 17<sup>th</sup>.

### SIMPLY COMPLETE THE FOLLOWING AND RETURN ASAP

PLEASE SEND AS SOON AS POSSIBLE.

#### THANK YOU

Individual placing ad \_\_\_\_\_  
Company or Organization \_\_\_\_\_

#### Mailing Address

Street \_\_\_\_\_  
City \_\_\_\_\_ State \_\_\_\_\_ Zip code \_\_\_\_\_  
Phone # \_\_\_\_\_ Email Address\* \_\_\_\_\_

**Mail to: JAY PALMER SCHOLARSHIP TRUST FUND**  
**C/O James Palmer, III**  
**6735 EAST OLD US HWY 64**  
**LEXINGTON, NC 27292**  
**FAX # (336) 746-5005 or**

**E-mail to: james\_marie@lexcominc.net**  
**Questions – Call James Palmer, III**  
**336-746-5000 res.**  
**336-239-1315 cell**

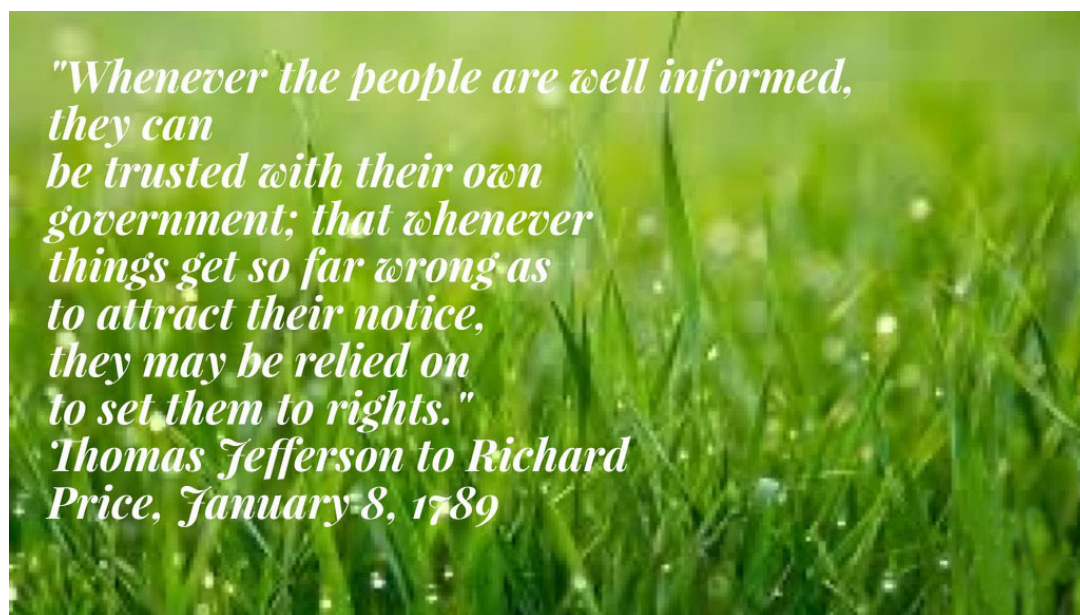

## 20<sup>TH</sup> ANNUAL JAY PALMER SCHOLARSHIP GOLF TOURNAMENT REGISTRATION FORM

**Sponsored by: Premier Supply, Inc.**

**Date: Thursday**  
**23 September, 2021**

**Place:** Star Hill Golf and Country Club  
202 Club House Dr, Cape Carteret, NC

**Entrance Fees: \$50**  
*(Due on Tournament Date ...  
this includes Cart and Green Fees)*  
Scores will be handicapped by Callaway System

**• SPECIAL NOTICE •**  
**Starting times will be arranged beginning at 8:00 AM**  
**Please be on site around 7:30 AM**

**TROPHIES & or PRIZES**  
\*Low Gross - 1<sup>st</sup> and 2<sup>nd</sup>  
\*Low Net - 1<sup>st</sup> and 2<sup>nd</sup>  
\*Longest Drive \*Closest to Pin  
Prizes and Awards

**(Maintenance personnel only, Eligible for prizes)**  
**Complete and Return Your Application**  
**PRIOR TO 17 AUGUST, 2021 (IF POSSIBLE)**  
Course requesting numbers of players

Name - \_\_\_\_\_

Address - \_\_\_\_\_

School System Name - \_\_\_\_\_ District # \_\_\_\_\_

Company Name - \_\_\_\_\_

Return to:  
**Tournament Director:**  
Jay Palmer Scholarship Trust Fund  
C/O James Palmer, III  
6735 East Old US Hwy 64  
Lexington, NC 27292  
Phone: 336-746-5000  
Fax: 336-746-5005  
Cell: 336-239-1315

# GUIDELINES FOR TOP AWARDS

Nominations are being sought for the 2021 NCPSMA Maintenance Director of the Year, Maintenance Employee of the Year and Superintendent of the Year. The Maintenance Director of the Year and Maintenance Employee of the Year awards were established 34 years ago by Milt Saffelle and are sponsored annually by Saffelle, Inc. This is the 25th year the Superintendent of the Year award has been sponsored by Saffelle, Inc.

Should you wish to nominate a candidate, please supply the information outlined below and return to the chairman of the NCPSMA Awards Committee by **August 10, 2021**. To qualify as a candidate for Superintendent of the Year, candidates may be superintendents, associate/assistant superintendents, who have the responsibilities for maintenance. They must be current members of NCPSMA.

Maintenance Directors are defined as those who serve as **direct head** of the maintenance department. Maintenance Employees are defined as other members of maintenance staff.

1. Nominees for Supervisor of the Year or Employee of the Year awards must be currently employed as a maintenance person in an educational system in the state of North Carolina.
2. The nominee must have been an active member of the NCPSMA for the last five **consecutive** years.
3. The nominee cannot be the current state president.
4. Nominations must be made by an active member of NCPSMA. There should be a letter of nomination signed by the active member. Only one nominee, per category, may be submitted from each LEA. If more than one nominee, per category, from an individual LEA is submitted, same category nominations from said LEA will be **disqualified**. This decision was passed by the NCPSMA Advisory Council, May 2016.
5. Nominees must be from the NCPSMA **District** making the nomination.
6. The following data must be supplied for each candidate:
  - A photograph of the nominee must be included and placed on a separate sheet of paper.
  - A biographical sketch, preferably in narrative form and no more than two pages in length, including the nominee's achievements that have contributed to success in NCPSMA and other professional involvement.
  - No other information on nominee will be accepted.

The Awards Committee is comprised of the NCPSMA One Year Advisory Council Members and Milt Saffelle, chairman. Saffelle serves in an exofficio capacity and does not have voting privileges. In case of a tie the current state vice president will have voting privileges. All nominations must be submitted no later than **August 10, 2021** to: Milton Saffelle, Chairman, NCPSMA Awards Committee, PO Box 1499, Hillsborough, NC 27278.

## EASTERN CONVENTION ROOM RESERVATIONS

**Don't Delay – Our room block will go quickly.**

We have a contract with DoubleTree by Hilton, Atlantic Beach, NC. The rate starts at \$129.00 per night. The phone number for reservations is 1-800-222-TREE or 252-240-1155. The link for online reservations is: <http://group.doubletree.com/PSM>

DoubleTree by Hilton  
2717 West Fort Macon Road  
Atlantic Beach, North Carolina, 28512

## KEN STALEY COMPANY, LTD

4675 ROUTE 64 • BUILDING #16 • FRANKLINVILLE • NC 27248 • [www.bleacher101.com](http://www.bleacher101.com)

OFFICE: 336.685.4294 • FAX: 336.685.4242 • EMAIL: [bleacher101@hotmail.com](mailto:bleacher101@hotmail.com)

# BLEACHERS

## GYM & OUTDOOR

- Safety Inspection & Repair Work
- Annual Service Program Offered • Handicap Areas
- Full Power Electrical Systems • Portable Power Systems
- Safety Rails • Outdoor Seating Sales and Installation
- Authorized & Certified • Bleacher Installers
- Basketball Goals Installed and Repaired

**MORE THAN 40 YEARS OF SERVICE**

SEE US FOR ALL OF YOUR BLEACHER NEEDS!

**SEVEN OAKS DOORS & HARDWARE, INC.**  
[www.SevenOaksHardware.com](http://www.SevenOaksHardware.com)

Call us for all your doors, hardware, access control, and toilet partition needs.

Oakboro, NC  
**704-485-2014**

Authorized Security Center  
ALLEGION

**SKY**  
Cooling Towers  
Hot & Cold Water Loops  
Pumps  
Timers  
Softners  
Boilers  
Controllers

**SKY ENTERPRISES, INC.** (252) 522-1435 • 1-800-729-0590  
Water Treatment Specialist PO Box 1764 • Kinston, N.C. 28503

**HOFFMAN & HOFFMAN, INC.**

## MAKING INDOOR AIR SAFER

HVAC system solutions to improve your indoor air quality and help protect building occupants.

Solutions from trusted manufacturer's like:

**BIG ASS FANS** **GPS** **PRICE** **camfil** **DAIKIN**

24/7/365 Parts Available  
(800) 332-2295

[www.hoffman-hoffman.com](http://www.hoffman-hoffman.com) (336) 292-8777

**Atlantic Coastal Supply, Inc.**  
Plumbing & Industrial Specialties

[www.acsparts.net](http://www.acsparts.net)  
PO Box 2887  
Greenville, NC 27836  
Phone: 800.520.0556 • Fax: 800.204.5630 • Email: [sales@atlanticcoastalsupply.com](mailto:sales@atlanticcoastalsupply.com)

**JMP**  
HYDRONIC AND STEAM EQUIPMENT, PUMPS, HEAT EXCHANGERS, COOLING TOWERS, WATER SOURCE HEAT PUMPS, PLUMBING

**CLIMATEMASTER** Geothermal Heat Pump Systems  
**Lochinvar** CONDENSING BOILERS WATER HEATERS  
**HYFAB** HYDRONIC PACKAGES PRESSURE BOOSTERS  
**B&G** Bell & Gossett CENTRIFUGAL PUMPS HEAT EXCHANGERS  
**BAC** COOLING TOWERS

James M. Pleasants Company  
Greensboro-Charlotte-Raleigh-Wilmington  
[www.jmpco.com](http://www.jmpco.com)  
800-365-9010

**“Responding to Modern Engineering Challenges With Innovative, Cost Effective Solutions”**

**RNM ENGINEERS**  
Reece, Noland & McElrath, Inc.  
409 North Haywood Street / PO Box 540  
Waynesville, NC 28786  
Waynesville (828) 456-9851 Asheville (828) 253-3280  
Fax (828) 456-6205  
[WWW.RNM-ENGINEERS.COM](http://WWW.RNM-ENGINEERS.COM)

# 49<sup>TH</sup> ANNUAL NCPSMA EASTERN CONVENTION/WORKSHOP AGENDA

DoubleTree by Hilton / Atlantic Beach, NC

September 22-24, 2021 • Tentative Agenda

## Tuesday 9/21

6:00-7:00 Early Registration -Foyer

## Wednesday 9/22

7:00-5:00 Registration -Foyer

8:00-10:00 **Locksmith License Renewal**  
(2 CEU's - must attend all classes)  
*Presented by ASSA Abloy*

*Pamlico & Hatteras* **Electrical** (2 CEU's -must attend all 4 classes)  
*Presented by Danny R. McManus Jr., Union County Schools Facilities Assistant Director*

*Bogue Sound* **Ornamental & Turf Pest Control**  
(2 CEU's -must attend both classes)  
*Presented by Tom Glasgow, Craven County Extension Director/ Horticulture Agent, NC State University*

10:15-12:15 **Locksmith License Renewal**  
(2 CEU's - must attend all classes)  
*Presented by ASSA Abloy*

*Pamlico & Hatteras* **Electrical** (2 CEU's -must attend all 4 classes)  
*Presented by Danny R. McManus Jr., Union County Schools Facilities Assistant Director*

*Bogue Sound* **Ornamental & Turf Pest Control**  
(2 CEU's - must attend both classes)  
*Presented by Shawn Banks, Presented by Carteret County Extension Director/ Horticulture Agent, NC State University*

10:15-12:15 **Press Fittings in the Plumbing World-Installation & Application**  
*Presented by Andreas Adrian, Technical Manager, Mid-Atlantic/Southeast, Viega, LLC*

12:15 Lunch on Your Own

12:15-1:45 *Restaurant* Advisory Council Member Meeting

2:00-3:00 *Atlantic* Business Session

3:30-5:30 *Cape Fear* **Meeting Today's Code Compliance Requirements, Preventive Maintenance and Insuring Seating Safety**  
*Presented by Mark Beaulieu, Hussey Seating Company and Stephen Bishop, Seating Safety Solutions*

*Cape Lookout* **Boiler Systems and Service**  
(2 CEU's)  
*Presented by Jeff Miller, James M. Pleasants*

## Wednesday 9/22 continued

*Pamlico & Hatteras* **Electrical** (2 CEU's -must attend all 4 classes)  
*Presented by Danny R. McManus Jr., Union County Schools Facilities Assistant Director*

*Bogue Sound* **Structural Pest Control**  
(2 CEU's -must both classes)  
*Presenter TBA*

*Atlantic* **Locksmith License Renewal**  
*Presented by Seven Oaks D&H and Carl Jobe, Retired Guilford County Schools*

## Thursday 9/23

7:00 **33rd Annual Jay Palmer Memorial Scholarship Golf Tournament**

9:00-9:30 *Atlantic* **Exhibitor Display Selection**

9:30-11:00 *Atl/Fear/Lookout Pam/Hatt* **Exhibitor Display Setup**

*Bogue Sound* **Structural Pest Control** (2 CEU's)  
*Presenter TBA*

9:30-11:00 *Onslow* **Bleacher Codes, Inspections & Troubleshooting Tips**  
*Presented by Matt Knight, Facili-Serv*

11:00-12:00 **Superintendents & Directors visit with Exhibitors**

Noon Lunch on Your Own

12:00-1:00 **State Officers, Superintendents & Directors Luncheon**

1:00-5:00 **Visit with Exhibitors**

## Friday 9/24

8:00-4:00 Registration

8:00:10:00 **Breakfast with Exhibitors**

10:00 **Exhibitor Display Breakdown**

10:00-12:00 *Bogue Sound* **Emergency Response Planning**  
*Presented by Ben Bass, Builders Service*

*Onslow* **Maintenance Director/Supervisor Round Table Discussions**

12:00-1:30 *Courtyard* **Cornhole Tournament**  
(\$5 entry fee-includes bagged lunch)

1:30-3:30 *Pamlico & Hatteras* **Electrical** (2 CEU's -must attend all 4 classes)  
*Presented by Danny R. McManus Jr., Union County Schools Facilities Assistant Director*

1:30-3:30 *Bogue Sound* **Roof Coating Forensics-Problem Solving**  
*Presented by Fred Wolfe, Business Director, Everest Systems*

*Onslow* **Maintenance Director/Supervisor Round Table Discussions**

6:00-Until *Atlantic Cape Fear & Lookout* **Banquet**

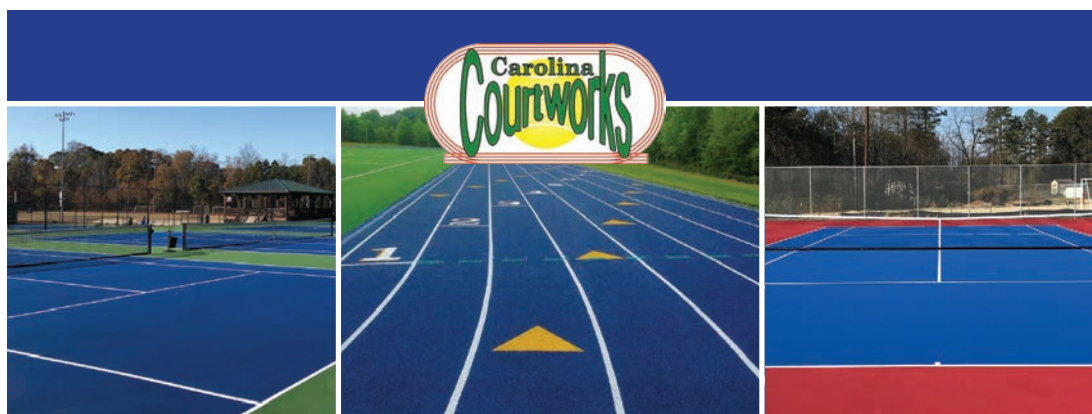

Carolina Courtworks is a licensed contractor of start to finish tennis and track complexes. From courts, fences, lighting, nets and other accessories, we can cover all your needs. If you're looking to resurface, reconstruct or construct we have been working in North and South Carolina for more than 27 years.

**Carolina Courtworks**  
carolinacourtworks.com

(704) 392-6556 | 8715 Sidney Circle, Suite 600 | Charlotte, NC 28269

# 49<sup>TH</sup> ANNUAL NCPSMA EASTERN CONVENTION/WORKSHOP INDIVIDUAL REGISTRATION FORM FOR \*REGULAR OR RETIRED REGULAR MEMBERS

September 22-24, 2021 \* DoubleTree by Hilton \* Atlantic Beach, NC

Current or Retired Employees must be a current member to attend. Registration check-in at the convention will go much quicker for you if your membership is current before you arrive.

**IMPORTANT INFORMATION – EACH PERSON attending the Awards Banquet (members as well as spouses, children, friends, etc., MUST PURCHASE a Banquet Ticket IN ADVANCE. NCPSMA welcomes members to bring their family or friends to our Awards Banquet, but you must purchase each person a Banquet Ticket (\$10 each) in advance. NCPSMA must provide DoubleTree a count for the Awards Banquet two weeks prior to the event and we only order meals for those who purchased a Banquet Ticket in advance because the Banquet meal price for each individual is around \$50. Please contact Roxie Mack if you have any questions at (336) 366-4939 or roxiermack@gmail.com.**

PLEASE PRINT

Name: \_\_\_\_\_ Name of School System (LEA): \_\_\_\_\_

Address: \_\_\_\_\_ City: \_\_\_\_\_ State: NC Zip \_\_\_\_\_

Office Phone: \_\_\_\_\_ FAX: \_\_\_\_\_ E-mail Address: \_\_\_\_\_

**\*REMINDER: If you would like to bring your spouse, children, friends, etc. to the Awards Banquet on Friday night, you MUST purchase a Banquet ticket in advance.**

Conference Fees: Please check all fees and items that apply and fill in blocks where appropriate.

PREREGISTRATION Before August 10, 2021		REGISTRATION After August 10, 2021		MEMBERSHIP		BANQUET TICKET MUST BE PURCHASED IN ADVANCE		TOTAL
Cash/Check	Credit/Debit	Cash/Check	Credit/Debit	Cash/Check	Credit/Debit	Cash/Check	Credit/Debit	
___ x \$75	___ x \$78	___ x \$85	___ x \$88	___ x \$20	___ x \$21	___ x \$10	___ x \$11	

**There will be no refunds after August 30, 2021.**

### Payment Information

**Checks:** Payable to NCPSMA and mail to NCPSMA, 630 Adams Ridge Road, State Road, NC 28676

**Credit/Debit Cards:** Please call Roxie Mack at (336) 366-939 with your information and the transaction will be completed online during the call. NCPSMA does not retain credit/debit card information. **Please email or fax a completed registration form before calling Roxie Mack.**

# 49<sup>TH</sup> ANNUAL NCPSMA EASTERN CONVENTION/WORKSHOP MULTIPLE REGISTRATION FORM FOR \*REGULAR OR RETIRED REGULAR MEMBERS

September 22-24, 2021 \* DoubleTree by Hilton \* Atlantic Beach, NC

Current or Retired Employees must be a current member to attend. Registration check-in at the convention will go much quicker for you if your membership is current before you arrive.

**IMPORTANT INFORMATION – EACH PERSON attending the Awards Banquet (members as well as spouses, children, friends, etc., MUST PURCHASE a Banquet Ticket IN ADVANCE. NCPSMA welcomes members to bring their family or friends to our Awards Banquet, but you must purchase each person a Banquet Ticket (\$10 each) in advance. NCPSMA must provide DoubleTree a count for the Awards Banquet two weeks prior to the event and we only order meals for those who purchased a Banquet Ticket in advance because the Banquet meal price for each individual is around \$50. Please contact Roxie Mack if you have any questions at (336) 366-4939 or roxiermack@gmail.com.**

PLEASE PRINT

Name: \_\_\_\_\_ Name of School System (LEA): \_\_\_\_\_

Address: \_\_\_\_\_ City: \_\_\_\_\_ State: NC Zip \_\_\_\_\_

Office Phone: \_\_\_\_\_ FAX: \_\_\_\_\_ E-mail Address: \_\_\_\_\_

**\*REMINDER: If you would like to bring your spouse, children, friends, etc. to the Awards Banquet on Friday night, you MUST purchase a Banquet ticket in advance.**

Conference Fees: Please check all fees and items that apply and fill in blocks where appropriate.

NAME	PREREGISTRATION Before August 10, 2021		REGISTRATION After August 10, 2021		MEMBERSHIP		BANQUET TICKET MUST BE PURCHASED IN ADVANCE		TOTAL
	Cash/Check	Credit/Debit	Cash/Check	Credit/Debit	Cash/Check	Credit/Debit	Cash/Check	Credit/Debit	
	x \$75	x \$78	x \$85	x \$88	x \$20	x \$21	x \$10	x \$11	
	Cash/Check	Credit/Debit	Cash/Check	Credit/Debit	Cash/Check	Credit/Debit	Cash/Check	Credit/Debit	
	x \$75	x \$78	x \$85	x \$88	x \$20	x \$21	x \$10	x \$11	
	Cash/Check	Credit/Debit	Cash/Check	Credit/Debit	Cash/Check	Credit/Debit	Cash/Check	Credit/Debit	
	x \$75	x \$78	x \$85	x \$88	x \$20	x \$21	x \$10	x \$11	
	Cash/Check	Credit/Debit	Cash/Check	Credit/Debit	Cash/Check	Credit/Debit	Cash/Check	Credit/Debit	
	x \$75	x \$78	x \$85	x \$88	x \$20	x \$21	x \$10	x \$11	
	Cash/Check	Credit/Debit	Cash/Check	Credit/Debit	Cash/Check	Credit/Debit	Cash/Check	Credit/Debit	
	x \$75	x \$78	x \$85	x \$88	x \$20	x \$21	x \$10	x \$11	
	Cash/Check	Credit/Debit	Cash/Check	Credit/Debit	Cash/Check	Credit/Debit	Cash/Check	Credit/Debit	
	x \$75	x \$78	x \$85	x \$88	x \$20	x \$21	x \$10	x \$11	
	Cash/Check	Credit/Debit	Cash/Check	Credit/Debit	Cash/Check	Credit/Debit	Cash/Check	Credit/Debit	
	x \$75	x \$78	x \$85	x \$88	x \$20	x \$21	x \$10	x \$11	
	Cash/Check	Credit/Debit	Cash/Check	Credit/Debit	Cash/Check	Credit/Debit	Cash/Check	Credit/Debit	
	x \$75	x \$78	x \$85	x \$88	x \$20	x \$21	x \$10	x \$11	
									<b>GRAND TOTAL</b>

**There will be no refunds after August 30, 2021.**

### Payment Information

**Checks:** Payable to NCPSMA and mail to NCPSMA, 630 Adams Ridge Road, State Road, NC 28676

**Credit/Debit Cards:** Please call Roxie Mack at (336) 366-939 with your information and the transaction will be completed online during the call. NCPSMA does not retain credit/debit card information. **Please email or fax a completed registration form before calling Roxie Mack.**

\*Regular or Regular/Retired members are those currently employed and/or retired members in/of a NC Public School System. All others must register through Roxie Mack at (336) 366-4939 (phone); (336) 366-4938 (FAX) or roxiermack@gmail.com.

For more information concerning this even please visit our website at [www.ncpsma.org](http://www.ncpsma.org).